

M393A2K40BB0
M393A2K40BB1
M393A4K40BB0
M393A4K40BB1

288pin Registered DIMM based on 8Gb B-die

78FBGA with Lead-Free & Halogen-Free
(RoHS compliant)

datasheet

SAMSUNG ELECTRONICS RESERVES THE RIGHT TO CHANGE PRODUCTS, INFORMATION AND SPECIFICATIONS WITHOUT NOTICE.

Products and specifications discussed herein are for reference purposes only. All information discussed herein is provided on an "AS IS" basis, without warranties of any kind.

This document and all information discussed herein remain the sole and exclusive property of Samsung Electronics. No license of any patent, copyright, mask work, trademark or any other intellectual property right is granted by one party to the other party under this document, by implication, estoppel or otherwise.

Samsung products are not intended for use in life support, critical care, medical, safety equipment, or similar applications where product failure could result in loss of life or personal or physical harm, or any military or defense application, or any governmental procurement to which special terms or provisions may apply.

For updates or additional information about Samsung products, contact your nearest Samsung office.

All brand names, trademarks and registered trademarks belong to their respective owners.

(c) 2015 Samsung Electronics Co., Ltd. All rights reserved.

Revision History

| <u>Revision No.</u> | <u>History</u> | <u>Draft Date</u> | <u>Remark</u> | <u>Editor</u> |
|---------------------|-------------------------------------------------------------------------------------------|-------------------|---------------|---------------|
| 1.0 | - First SPEC Release | Nov. 2014 | - | J.Y.Lee |
| 1.1 | - Change of Part Number (Speed bin "RC") | Jan. 2015 | - | J.Y.Lee |
| 1.2 | - Addition of VDDSPD tolerance on page 8 | Mar. 2015 | - | J.Y.Lee |
| 1.3 | - Addition of IDD value (M393A2K40BB0-CPB, M393A2K40BB1-CRC, M393A4K40BB1-CRC) on page 25 | Apr. 2015 | - | J.Y.Lee |

[Table Of Contents](#)**288pin Registered DIMM based on 8Gb B-die**

| | |
|-----------------------------------------------------------------------------|----|
| 1. DDR4 Registered DIMM Ordering Information | 4 |
| 2. Key Features..... | 4 |
| 3. Address Configuration | 4 |
| 4. Registered DIMM Pin Configurations (Front side/Back side)..... | 5 |
| 5. Pin Description | 6 |
| 6. ON DIMM Thermal Sensor | 6 |
| 7. Input/Output Functional Description..... | 7 |
| 8. Registering Clock Driver Specification..... | 9 |
| 8.1 Timing & Capacitance Values | 9 |
| 8.2 Clock Driver Characteristics | 9 |
| 9. Function Block Diagram:..... | 10 |
| 9.1 16GB, 2Gx72 Module (Populated as 1 rank of x4 DDR4 SDRAMs) | 10 |
| 9.2 32GB, 4Gx72 Module (Populated as 2 ranks of x4 DDR4 SDRAMs) | 11 |
| 10. Absolute Maximum Ratings | 13 |
| 10.1 Absolute Maximum DC Ratings..... | 13 |
| 11. AC & DC Operating Conditions..... | 13 |
| 11.1 Recommended DC Operating Conditions | 13 |
| 12. AC & DC Input Measurement Levels | 14 |
| 12.1 AC & DC Logic Input Levels for Single-Ended Signals | 14 |
| 12.2 AC and DC Input Measurement Levels : VREF Tolerances..... | 14 |
| 12.3 AC and DC Logic Input Levels for Differential Signals | 15 |
| 12.3.1. Differential Signals Definition | 15 |
| 12.3.2. Differential Swing Requirements for Clock (CK_t - CK_c) | 15 |
| 12.3.3. Single-ended Requirements for Differential Signals | 16 |
| 12.4 Slew Rate Definitions | 17 |
| 12.4.1. Slew Rate Definitions for Differential Input Signals (CK) | 17 |
| 12.5 Differential Input Cross Point Voltage..... | 18 |
| 12.6 Single-ended AC & DC Output Levels..... | 19 |
| 12.7 Differential AC & DC Output Levels..... | 19 |
| 12.8 Single-ended Output Slew Rate | 19 |
| 12.9 Differential Output Slew Rate | 20 |
| 12.10 Single-ended AC & DC Output Levels of Connectivity Test Mode | 21 |
| 12.11 Test Load for Connectivity Test Mode Timing | 21 |
| 13. DIMM IDD Specification Definition | 22 |
| 14. IDD SPEC Table | 25 |
| 15. Input/Output Capacitance | 27 |
| 16. Electrical Characteristics and AC Timing | 28 |
| 16.1 Speed Bins and CL, tRCD, tRP, tRC and tRAS for Corresponding Bin | 28 |
| 16.2 Speed Bin Table Note | 31 |
| 17. Timing Parameters by Speed Grade | 32 |
| 18. Physical Dimensions..... | 38 |
| 18.1 2Gx4 based 2Gx72 Module (1 Rank) - M393A2K40BB0/M393A2K40BB1 | 38 |
| 18.1.1. 2Gx72 DIMM, populated as one physical rank of x4 DDR4 SDRAMs | 38 |
| 18.2 2Gx4 based 4Gx72 Module (2 Ranks) - M393A4K40BB0/M393A4K40BB1 | 39 |
| 18.2.1. 4Gx72 DIMM, populated as two physical ranks of x4 DDR4 SDRAMs..... | 39 |

1. DDR4 Registered DIMM Ordering Information

| Part Number ² | Density | Organization | Component Composition ¹ | Number of Rank | Height |
|--------------------------------------|---------|--------------|------------------------------------|----------------|---------|
| M393A2K40BB0-CPB M393A2K40BB1-CRC | 16GB | 2Gx72 | 2Gx4(K4A8G045WB-BC##)*18 | 1 | 31.25mm |
| M393A4K40BB0-CPB M393A4K40BB1-CRC | 32GB | 4Gx72 | 2Gx4(K4A8G045WB-BC##)*36 | 2 | 31.25mm |

NOTE :

- "##" - PB/RC
- PB(2133Mbps 15-15-15)/RC(2400Mbps 17-17-17)
- DDR4-2400(17-17-17) is backward compatible to DDR4-2133(15-15-15)

2. Key Features

| Speed | DDR4-1600 | DDR4-1866 | DDR4-2133 | DDR4-2400 | Unit |
|-------------|-----------|-----------|-----------|-----------|------|
| | 11-11-11 | 13-13-13 | 15-15-15 | 17-17-17 | |
| tCK(min) | 1.25 | 1.071 | 0.938 | 0.833 | ns |
| CAS Latency | 11 | 13 | 15 | 17 | nCK |
| tRCD(min) | 13.75 | 13.92 | 14.06 | 14.16 | ns |
| tRP(min) | 13.75 | 13.92 | 14.06 | 14.16 | ns |
| tRAS(min) | 35 | 34 | 33 | 32 | ns |
| tRC(min) | 48.75 | 47.92 | 47.06 | 46.16 | ns |

- JEDEC standard 1.2V ± 0.06V Power Supply
- V_{DDQ} = 1.2V ± 0.06V
- 800 MHz f_{CK} for 1600Mb/sec/pin, 933 MHz f_{CK} for 1866Mb/sec/pin, 1067MHz f_{CK} for 2133Mb/sec/pin, 1200MHz f_{CK} for 2400Mb/sec/pin
- 16 Banks (4 Bank Groups)
- Programmable CAS Latency: 10,11,12,13,14,15,16,17,18
- Programmable Additive Latency(Posted CAS) : 0, CL - 2, or CL - 1 clock
- Programmable CAS Write Latency(CWL) = 9,11 (DDR4-1600) , 10,12 (DDR4-1866) , 11,14 (DDR4-2133) and 12,16 (DDR4-2400)
- Burst Length: 8 , 4 with tCCD = 4 which does not allow seamless read or write [either On the fly using A12 or MRS]
- Bi-directional Differential Data Strobe
- On Die Termination using ODT pin
- Average Refresh Period 7.8us at lower then T_{CASE} 85°C, 3.9us at 85°C < T_{CASE} ≤ 95°C
- Asynchronous Reset

3. Address Configuration

| Organization | Row Address | Column Address | Bank Group Address | Bank Address | Auto Precharge |
|------------------------|-------------|----------------|--------------------|--------------|----------------|
| 2Gx4(8Gb) based Module | A0-A16 | A0-A9 | BG0-BG1 | BA0-BA1 | A10/AP |

4. Registered DIMM Pin Configurations (Front side/Back side)

| Pin | Front | Pin | Back | Pin | Front | Pin | Back | Pin | Front | Pin | Back | Pin | Front | Pin | Back | |
|-----|----------------------|-----|----------------------|-----|----------------------|-----|---------|-----|----------------------|-----|-------------|-----|----------------------|-----|------------------|--|
| 1 | 12V ³ ,NC | 145 | 12V ³ ,NC | 40 | TDQS12_t, DQS12_t | 184 | VSS | 78 | EVENT_n | 222 | PARITY | 117 | DQ52 | 261 | VSS | |
| 2 | VSS | 146 | VREFCA | 41 | TDQS12_c, DQS12_c | 185 | DQS3_c | 79 | A0 | 223 | VDD | 118 | VSS | 262 | DQ53 | |
| 3 | DQ4 | 147 | VSS | 42 | VSS | 186 | DQS3_t | 80 | VDD | 224 | BA1 | 119 | DQ48 | 263 | VSS | |
| 4 | VSS | 148 | DQ5 | 43 | DQ30 | 187 | VSS | 81 | BA0 | 225 | A10/AP | 120 | VSS | 264 | DQ49 | |
| 5 | DQ0 | 149 | VSS | 44 | VSS | 188 | DQ31 | 82 | RAS_n/A16 | 226 | VDD | 121 | TDQS15_t, DQS15_t | 265 | VSS | |
| 6 | VSS | 150 | DQ1 | 45 | DQ26 | 189 | VSS | 83 | VDD | 227 | RFU | 122 | TDQS15_c, DQS15_c | 266 | DQS6_c | |
| 7 | TDQS9_t, DQS9_t | 151 | VSS | 46 | VSS | 190 | DQ27 | 84 | S0_n | 228 | WE_n/A14 | 123 | VSS | 267 | DQS6_t | |
| 8 | TDQS9_c, DQS9_c | 152 | DQS0_c | 47 | CB4 | 191 | VSS | 85 | VDD | 229 | VDD | 124 | DQ54 | 268 | VSS | |
| 9 | VSS | 153 | DQS0_t | 48 | VSS | 192 | CB5 | 86 | CAS_n/A15 | 230 | NC | 125 | VSS | 269 | DQ55 | |
| 10 | DQ6 | 154 | VSS | 49 | CB0 | 193 | VSS | 87 | ODT0 | 231 | VDD | 126 | DQ50 | 270 | VSS | |
| 11 | VSS | 155 | DQ7 | 50 | VSS | 194 | CB1 | 88 | VDD | 232 | A13 | 127 | VSS | 271 | DQ51 | |
| 12 | DQ2 | 156 | VSS | 51 | TDQS17_t, DQS17_t | 195 | VSS | 89 | S1_n | 233 | VDD | 128 | DQ60 | 272 | VSS | |
| 13 | VSS | 157 | DQ3 | 52 | TDQS17_c, DQS17_c | 196 | DQS8_c | 90 | VDD | 234 | A17 | 129 | VSS | 273 | DQ61 | |
| 14 | DQ12 | 158 | VSS | 53 | VSS | 197 | DQS8_t | 91 | ODT1 | 235 | NC,C2 | 130 | DQ56 | 274 | VSS | |
| 15 | VSS | 159 | DQ13 | 54 | CB6 | 198 | VSS | 92 | VDD | 236 | VDD | 131 | VSS | 275 | DQ57 | |
| 16 | DQ8 | 160 | VSS | 55 | VSS | 199 | CB7 | 93 | C0,CS2_n,NC | 237 | NC,CS3_c,C1 | 132 | TDQS16_t, DQS16_t | 276 | VSS | |
| 17 | VSS | 161 | DQ9 | 56 | CB2 | 200 | VSS | 94 | VSS | 238 | SA2 | 133 | TDQS16_c, DQS16_c | 277 | DQS7_c | |
| 18 | TDQS10_t, DQS10_t | 162 | VSS | 57 | VSS | 201 | CB3 | 95 | DQ36 | 239 | VSS | 134 | VSS | 278 | DQS7_t | |
| 19 | TDQS10_c, DQS10_c | 163 | DQS1_c | 58 | RESET_n | 202 | VSS | 96 | VSS | 240 | DQ37 | 135 | DQ62 | 279 | VSS | |
| 20 | VSS | 164 | DQS1_t | 59 | VDD | 203 | CKE1 | 97 | DQ32 | 241 | VSS | 136 | VSS | 280 | DQ63 | |
| 21 | DQ14 | 165 | VSS | 60 | CKE0 | 204 | VDD | 98 | VSS | 242 | DQ33 | 137 | DQ58 | 281 | VSS | |
| 22 | VSS | 166 | DQ15 | 61 | VDD | 205 | RFU | 99 | TDQS13_t, DQS13_t | 243 | VSS | 138 | VSS | 282 | DQ59 | |
| 23 | DQ10 | 167 | VSS | 62 | ACT_n | 206 | VDD | 100 | TDQS13_c, DQS13_c | 244 | DQS4_c | 139 | SA0 | 283 | VSS | |
| 24 | VSS | 168 | DQ11 | 63 | BG0 | 207 | BG1 | 101 | VSS | 245 | DQS4_t | 140 | SA1 | 284 | VDDSPD | |
| 25 | DQ20 | 169 | VSS | 64 | VDD | 208 | ALERT_n | 102 | DQ38 | 246 | VSS | 141 | SCL | 285 | SDA | |
| 26 | VSS | 170 | DQ21 | 65 | A12/BC_n | 209 | VDD | 103 | VSS | 247 | DQ39 | 142 | VPP | 286 | VPP | |
| 27 | DQ16 | 171 | VSS | 66 | A9 | 210 | A11 | 104 | DQ34 | 248 | VSS | 143 | VPP | 287 | VPP | |
| 28 | VSS | 172 | DQ17 | 67 | VDD | 211 | A7 | 105 | VSS | 249 | DQ35 | 144 | RFU | 288 | VPP ⁴ | |
| 29 | TDQS11_t, DQS11_t | 173 | VSS | 68 | A8 | 212 | VDD | 106 | DQ44 | 250 | VSS | | | | | |
| 30 | TDQS11_c, DQS11_c | 174 | DQS2_c | 69 | A6 | 213 | A5 | 107 | VSS | 251 | DQ45 | | | | | |
| 31 | VSS | 175 | DQS2_t | 70 | VDD | 214 | A4 | 108 | DQ40 | 252 | VSS | | | | | |
| 32 | DQ22 | 176 | VSS | 71 | A3 | 215 | VDD | 109 | VSS | 253 | DQ41 | | | | | |
| 33 | VSS | 177 | DQ23 | 72 | A1 | 216 | A2 | 110 | TDQS14_t, DQS14_t | 254 | VSS | | | | | |
| 34 | DQ18 | 178 | VSS | 73 | VDD | 217 | VDD | 111 | TDQS14_c, DQS14_c | 255 | DQS5_c | | | | | |
| 35 | VSS | 179 | DQ19 | 74 | CK0_t | 218 | CK1_t | 112 | VSS | 256 | DQS5_t | | | | | |
| 36 | DQ28 | 180 | VSS | 75 | CK0_c | 219 | CK1_c | 113 | DQ46 | 257 | VSS | | | | | |
| 37 | VSS | 181 | DQ29 | 76 | VDD | 220 | VDD | 114 | VSS | 258 | DQ47 | | | | | |
| 38 | DQ24 | 182 | VSS | 77 | VTT | 221 | VTT | 115 | DQ42 | 259 | VSS | | | | | |
| 39 | VSS | 183 | DQ25 | KEY | | | | 116 | VSS | 260 | DQ43 | | | | | |

NOTE:

1. VPP is 2.5V DC
2. Pin 230 is defined as NC for UDIMMs, RDIMMs and LRDIMMs. Pin 230 is defined as SAVE_n for NVDIMMs.
3. Pins 1 and 145 are defined as NC for UDIMMs, RDIMMs and LRDIMMs. Pins 1 and 145 are defined as 12V for Hybrid /NVDIMM
4. The 5th VPP is required on all modules. DIMMs.

5. Pin Description

| Pin Name | Description | Pin Name | Description |
|----------------------------|---------------------------------------------------------------|----------|--------------------------------------------------|
| A0–A17 ¹ | Register address input | SCL | I2C serial bus clock for SPD/TS and register |
| BA0, BA1 | Register bank select input | SDA | I2C serial bus data line for SPD/TS and register |
| BG0, BG1 | Register bank group select input | SA0–SA2 | I2C slave address select for SPD/TS and register |
| RAS_n ² | Register row address strobe input | PAR | Register parity input |
| CAS_n ³ | Register column address strobe input | VDD | SDRAM core power supply |
| WE_n ⁴ | Register write enable input | VPP | SDRAM activating power supply |
| CS0_n, CS1_n, CS2_n, CS3_n | DIMM Rank Select Lines input | VREFCA | SDRAM command/address reference supply |
| CKE0, CKE1 | Register clock enable lines input | VSS | Power supply return (ground) |
| ODT0, ODT1 | Register on-die termination control lines input | VDDSPD | Serial SPD/TS positive power supply |
| ACT_n | Register input for activate input | ALERT_n | Register ALERT_n output |
| DQ0–DQ63 | DIMM memory data bus | RESET_n | Set Register and SDRAMs to a Known State |
| CB0–CB7 | DIMM ECC check bits | EVENT_n | SPD signals a thermal event has occurred |
| DQS0_t–DQS17_t | Data Buffer data strobes (positive line of differential pair) | VTT | SDRAM I/O termination supply |
| DQS0_c–DQS17_c | Data Buffer data strobes (negative line of differential pair) | RFU | Reserved for future use |
| CK0_t, CK1_t | Register clock input (positive line of differential pair) | | |
| CK0_c, CK1_c | Register clocks input (negative line of differential pair) | | |

NOTE :

1. Address A17 is only valid for 16 Gb x4 based SDRAMs.
2. RAS_n is a multiplexed function with A16.
3. CAS_n is a multiplexed function with A15.
4. WE_n is a multiplexed function with A14.

6. ON DIMM Thermal Sensor

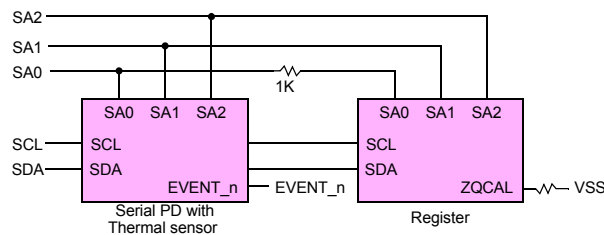

NOTE : 1. All Samsung RDIMM support Thermal sensor on DIMM

[Table 1] Temperature Sensor Characteristics

| Grade | Range | Temperature Sensor Accuracy | | | Units | NOTE |
|------------|----------------|-----------------------------|---------|---------|---------|------|
| | | Min. | Typ. | Max. | | |
| B | 75 < Ta < 95 | - | +/- 0.5 | +/- 1.0 | °C | - |
| | 40 < Ta < 125 | - | +/- 1.0 | +/- 2.0 | | - |
| | -20 < Ta < 125 | - | +/- 2.0 | +/- 3.0 | | - |
| Resolution | | 0.25 | | | °C /LSB | - |

7. Input/Output Functional Description

| Symbol | Type | Function |
|--------------------------------------|-------------------|-----------------------------------------------------------------------------------------------------------------------------------------------------------------------------------------------------------------------------------------------------------------------------------------------------------------------------------------------------------------------------------------------------------------------------------------------------------------------------------------------------------------------------------------------------------------------------------------------------------------------------------------------------------------------------------------------------------------|
| CK0_t, CK0_c, CK1_t, CK1_c | Input | Clock: CK_t and CK_c are differential clock inputs. All address and control input signals are sampled on the crossing of the positive edge of CK_t and negative edge of CK_c. |
| CKE0, CKE1 | Input | Clock Enable: CKE HIGH activates and CKE LOW deactivates internal clock signals and device input buffers and output drivers. Taking CKE LOW provides Precharge Power-Down and Self-Refresh operation (all banks idle), or Active Power-Down (row Active in any bank). CKE is synchronous for Self-Refresh exit. After VREFCA and Internal DQ Vref have become stable during the power on and initialization sequence, they must be maintained during all operations (including Self-Refresh). CKE must be maintained high throughout read and write accesses. Input buffers, excluding CK_t, CK_c, ODT and CKE, are disabled during power-down. Input buffers, excluding CKE, are disabled during Self-Refresh. |
| CS0_n, CS1_n, CS2_n, CS3_n | Input | Chip Select: All commands are masked when CS_n is registered HIGH. CS_n provides for external Rank selection. CS_n is considered part of the command code. |
| C0, C1, C2 | Input | Chip ID : Chip ID is only used for 3DS for 2,4,8 high stack via TSV to select each slice of stacked component. Chip ID is considered part of the command code. |
| ODT0, ODT1 | Input | On Die Termination: ODT (registered HIGH) enables RTT_NOM termination resistance internal to the DDR4 SDRAM. When enabled, ODT is only applied to each DQ, DQS_t, DQS_c, TDQS_t and TDQS_c signal. The ODT pin will be ignored if MR1 is programmed to disable RTT_NOM. |
| ACT_n | Input | Activation Command Input : ACT_n defines the Activation command being entered along with CS_n. The input into RAS_n/A16, CAS_n/A15 and WE_n/A14 will be considered as Row Address A16, A15 and A14 |
| RAS_n/A16. CAS_n/A15. WE_n/A14 | Input | Command Inputs: RAS_n/A16, CAS_n/A15 and WE_n/A14 (along with CS_n) define the command being entered. Those pins have multi function. For example, for activation with ACT_n Low, these are Addresses like A16, A15 and A14 but for non-activation command with ACT_n High, these are Command pins for Read, Write and other command defined in command truth table |
| BG0 - BG1 | Input | Bank Group Inputs: BG0 - BG1 define which bank group an Active, Read, Write or Precharge command is being applied. BG0 also determines which mode register is to be accessed during a MRS cycle. |
| BA0 - BA1 | Input | Bank Address Inputs: BA0 - BA1 define to which bank an Active, Read, Write or Precharge command is being applied. Bank address also determines which mode register is to be accessed during a MRS cycle. |
| A0 - A17 | Input | Address Inputs: Provide the row address for ACTIVATE Commands and the column address for Read/Write commands to select one location out of the memory array in the respective bank. A10/AP, A12/BC_n, RAS_n/A16, CAS_n/A15 and WE_n/A14 have additional functions. See other rows. The address inputs also provide the op-code during Mode Register Set commands. A17 is only defined for 16 Gb x4 SDRAM configurations. |
| A10 / AP | Input | Auto-precharge: A10 is sampled during Read/Write commands to determine whether Autoprecharge should be performed to the accessed bank after the Read/Write operation. (HIGH: Autoprecharge; LOW: no Autoprecharge). A10 is sampled during a Precharge command to determine whether the Precharge applies to one bank (A10 LOW) or all banks (A10 HIGH). If only one bank is to be precharged, the bank is selected by bank addresses. |
| A12 / BC_n | Input | Burst Chop: A12/BC_n is sampled during Read and Write commands to determine if burst chop (on-the-fly) will be performed. (HIGH, no burst chop; LOW: burst chopped). See command truth table for details. |
| RESET_n | CMOS Input | Active Low Asynchronous Reset: Reset is active when RESET_n is LOW, and inactive when RESET_n is HIGH. RESET_n must be HIGH during normal operation. |
| DQ | Input/ Output | Data Input/ Output: Bi-directional data bus. If CRC is enabled via Mode register then CRC code is added at the end of Data Burst. Any DQ from DQ0-DQ3 may indicate the internal Vref level during test via Mode Register Setting MR4 A4=High. Refer to vendor specific data sheets to determine which DQ is used. |
| DQS0_t-DQS17_t, DQS0_c-DQS17_c | Input/ Output | Data Strobe: output with read data, input with write data. Edge-aligned with read data, centered in write data. The data strobe DQS_t is paired with differential signals DQS_c, respectively, to provide differential pair signaling to the system during reads and writes. DDR4 SDRAM supports differential data strobe only and does not support single-ended. |
| PAR | Input | Command and Address Parity Input: DDR4 Supports Even Parity check in SDRAMs with MR setting. Once it's enabled via Register in MR5, then SDRAM calculates Parity with ACT_n, RAS_n/A16, CAS_n/A15, WE_n/A14, BG0-BG1, BA0-BA1, A17-A0. Input parity should be maintained at the rising edge of the clock and at the same time with command & address with CS_n LOW |
| ALERT_n | Output (Input) | Alert : It has multi functions such as CRC error flag, Command and Address Parity error flag as Output signal. If there is error in CRC, then ALERT_n goes LOW for the period time interval and goes back HIGH. If there is error in Command Address Parity Check, then ALERT_n goes LOW for relatively long period until on going SDRAM internal recovery transaction is complete. During Connectivity Test mode this pin functions as an input. Using this signal or not is dependent on the system. If the SDRAM ALERT_n pins are not connected to the ALERT_n pin on the edge connector is must still be connected to VDD on DIMM. |
| RFU | | Reserved for Future Use: No on DIMM electrical connection is present |
| NC | | No Connect: No on DIMM electrical connection is present |

| Symbol | Type | Function |
|------------------|--------|----------------------------------------------------------------------------------------------|
| VDD ¹ | Supply | Power Supply: 1.2 V \pm 0.06 V |
| VSS | Supply | Ground |
| VTT | Supply | VDD/2 |
| VPP | Supply | SDRAM Activating Power Supply: 2.5V (2.375V min, 2.75V max) |
| VDDSPD | Supply | SPD and register supply voltage. Register requires the nominal voltage to be 2.5V \pm 10%. |
| VREFCA | Supply | Reference voltage for CA |

NOTE :

1. For PC4 VDD is 1.2V. For PC4L VDD is TBD.

8. Registering Clock Driver Specification

8.1 Timing & Capacitance Values

| Symbol | Parameter | Conditions | DDR4-1600/1866/2133 | | DDR4-2400 | | Units | Notes |
|----------------------------------|---------------------------------------------------------------|----------------------------------------------------------------------------|-----------------------------------------------|------|-----------------------------------------------|------|-----------------|-------|
| | | | Min | Max | Min | Max | | |
| f _{clock} | Input Clock Frequency | application frequency | 625 | 1080 | 625 | 1350 | MHz | |
| t _{CH} /t _{CL} | Pulse duration, CK_t, CK_c HIGH or LOW | | 0.4 | - | 0.4 | - | t _{CK} | |
| t _{ACT} | Inputs active time ⁴ before DRST_n is taken HIGH | DCKE0/1 = LOW and DCS0/1_n = HIGH | 8 | - | 8 | - | t _{CK} | |
| t _{PDM} | Propagation delay, single-bit switching, CK_t/ CK_c to output | 1.2V Operation | 1 | 1.3 | 1 | 1.3 | ns | |
| t _{DIS} | output disable time | Rising edge of Yn_t to output float | 0.5*t _{CK} + t _{QSK1} (min) | - | 0.5*t _{CK} + t _{QSK1} (min) | - | ps | |
| t _{EN} | output enable time | Output valid to rising edge of Yn_t | 0.5*t _{CK} - t _{QSK1} (max) | - | 0.5*t _{CK} - t _{QSK1} (max) | - | ps | |
| C _I | Input capacitance, Data inputs | NOTE ^{1,2} | 0.8 | 1.1 | 0.8 | 1.0 | pF | |
| C _{CK} | Input capacitance, CK_t, CK_c | NOTE ^{1,2} | 0.8 | 1.1 | 0.8 | 1.0 | | |
| C _{IR} | Input capacitance, DRST_n | V _I =V _{DD} or V _{SS} ; V _{DD} =1.2V | 0.5 | 2.0 | 0.5 | 2.0 | | |

Note:

1. This parameter does not include package capacitance

2. Data inputs are DCKE0/1, DODT0/1, DA0..DA17, DBA0..DBA1, DBG0..DBG1, DACT_n, DC0..DC2, DPAR, DCS0/1_n

8.2 Clock Driver Characteristics

| Symbol | Parameter | Conditions | DDR4-1600/1866/2133 | | DDR4-2400 | | Units | Notes |
|-------------------------|-----------------------------------------|------------------|--------------------------|-------------------------|--------------------------|-------------------------|-------|-------|
| | | | Min | Max | Min | Max | | |
| t _{jit} (cc) | Cycle-to-cycle period jitter | CK_t/CK_c stable | 0 | 0.025 x t _{CK} | 0 | 0.025 x t _{CK} | ps | |
| t _{STAB} | Stabilization time | | - | 5 | - | 5 | us | |
| t _{CKsk} | Clock Output skew | | - | 10 | - | 10 | ps | |
| t _{jit} (per) | Yn Clock Period jitter | | -0.025 * t _{CK} | 0.025 * t _{CK} | -0.025 * t _{CK} | 0.025 * t _{CK} | ps | |
| t _{jit} (hper) | Half period jitter | | -0.032 * t _{CK} | 0.032 * t _{CK} | -0.032 * t _{CK} | 0.032 * t _{CK} | ps | |
| t _{Qsk1} | Qn Output to clock tolerance | | -0.125 * t _{CK} | 0.125 * t _{CK} | -0.125 * t _{CK} | 0.125 * t _{CK} | ps | |
| t _{dynoff} | Maximum re-driven dynamic clock off-set | | - | 50 | - | 45 | ps | |

9. Function Block Diagram:

9.1 16GB, 2Gx72 Module (Populated as 1 rank of x4 DDR4 SDRAMs)

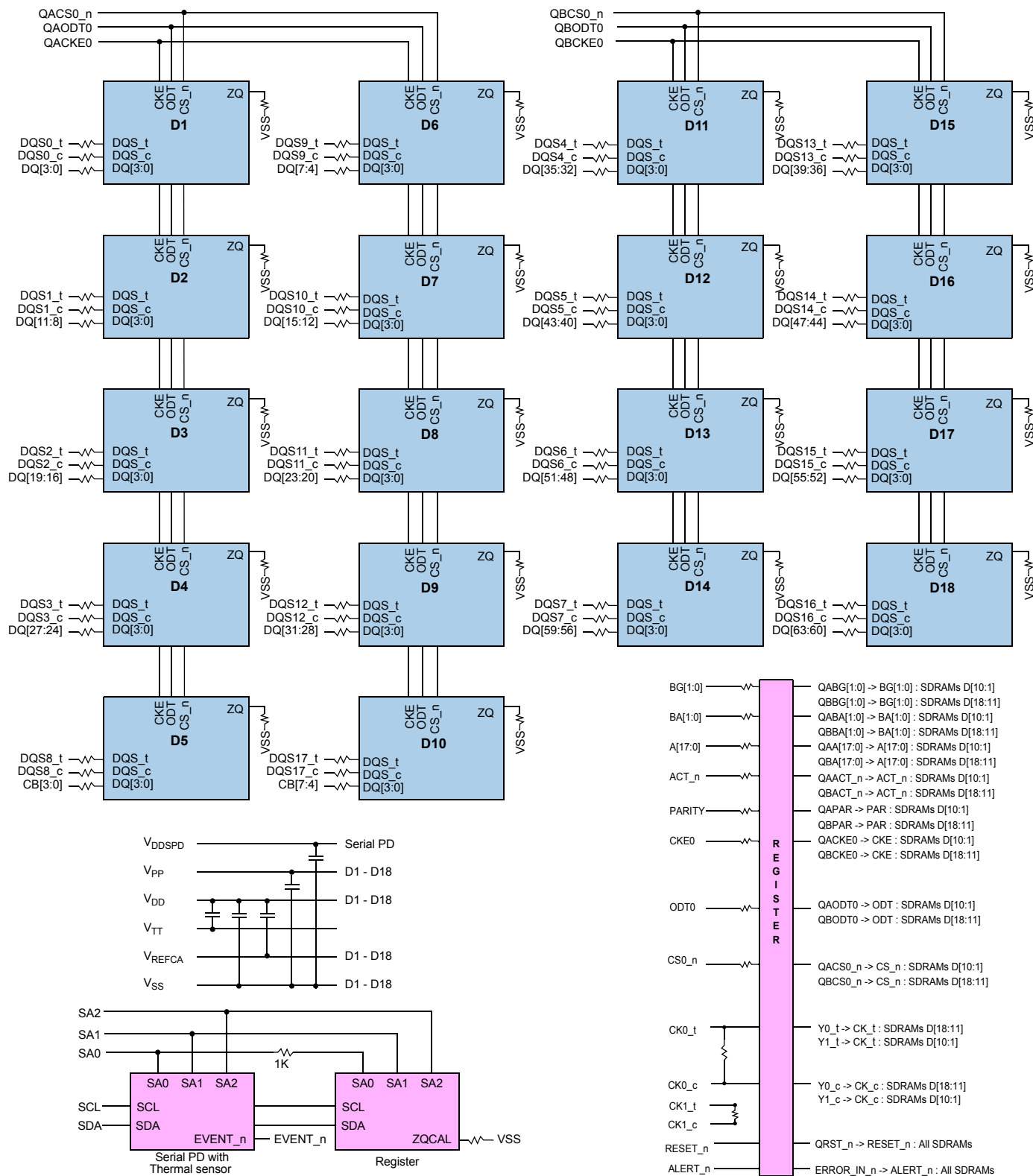

NOTE :

1. Unless otherwise noted, resistor values are 15Ω ± 5%.
2. See the Net Structure diagrams for all resistors associated with the command, address and control bus.
3. ZQ resistors are 240Ω ± 1% . For all other resistor values refer to the appropriate wiring diagram.

9.2 32GB, 4Gx72 Module (Populated as 2 ranks of x4 DDR4 SDRAMs)

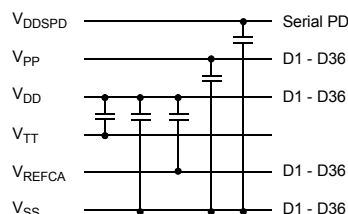
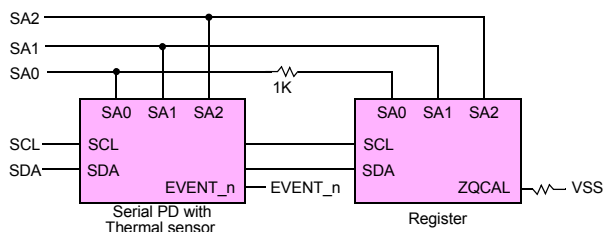
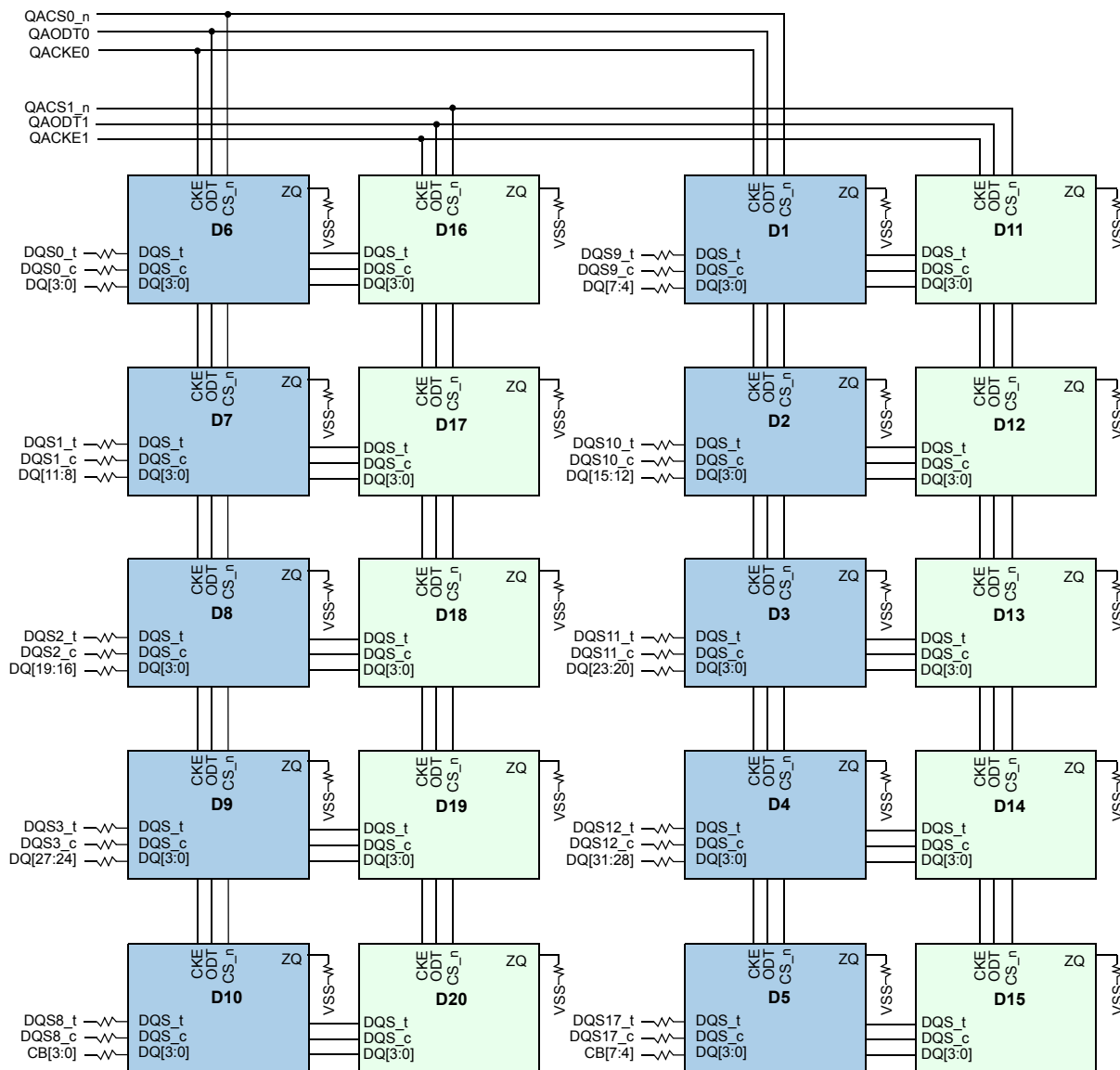

NOTE :

1. Unless otherwise noted, resistor values are $15\Omega \pm 5\%$.
2. See the Net Structure diagrams for all resistors associated with the command, address and control bus.
3. ZQ resistors are $240\Omega \pm 1\%$. For all other resistor values refer to the appropriate wiring diagram.

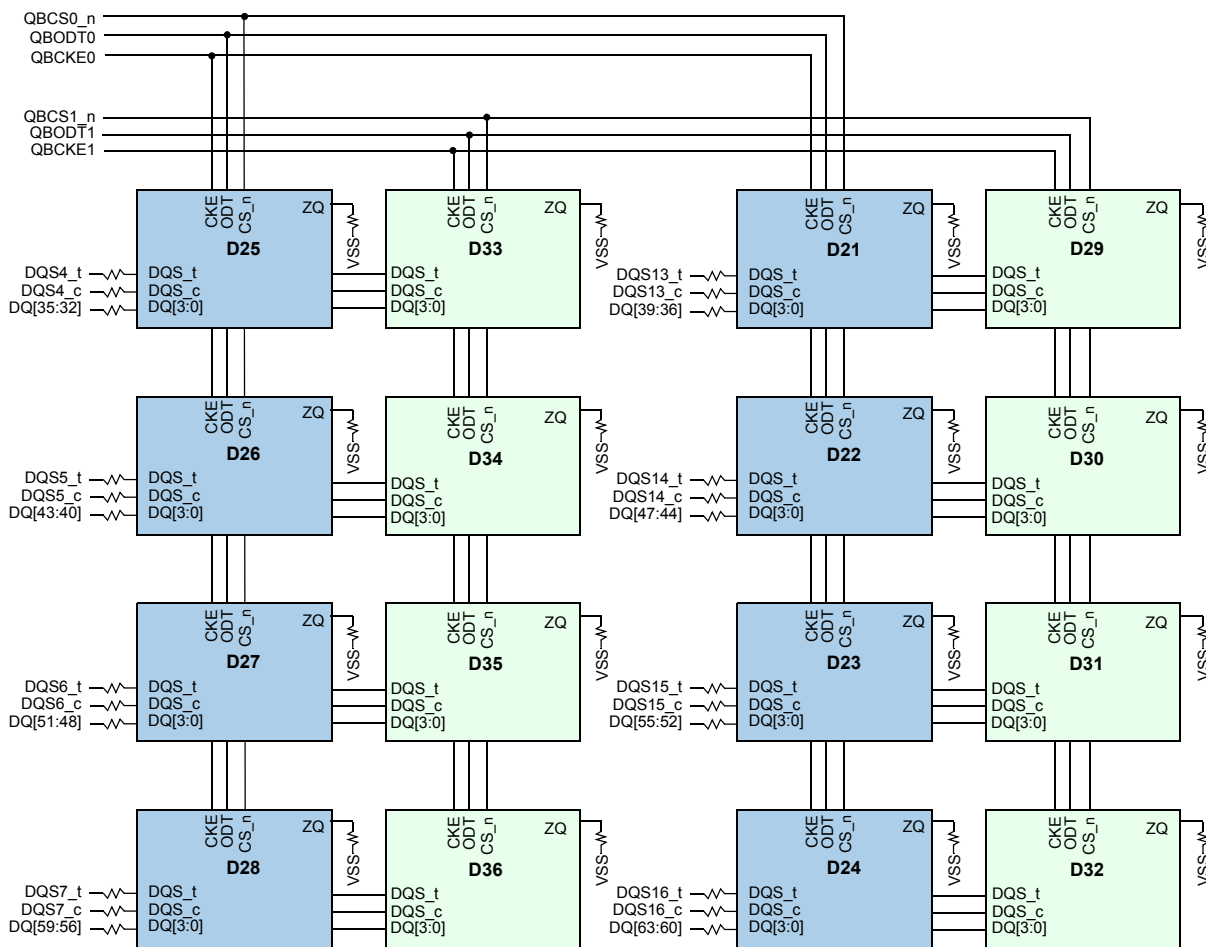

| | |
|-----------|------------------------------------------|
| BG[1:0] | QABG[1:0] -> BG[1:0] : SDRAMs D[20:1] |
| QBBG[1:0] | QBBG[1:0] -> BG[1:0] : SDRAMs D[36:21] |
| BA[1:0] | QABA[1:0] -> BA[1:0] : SDRAMs D[20:1] |
| QBBA[1:0] | QBBA[1:0] -> BA[1:0] : SDRAMs D[36:21] |
| A[17:0] | QAA[17:0] -> A[17:0] : SDRAMs D[20:1] |
| QBA[17:0] | QBA[17:0] -> A[17:0] : SDRAMs D[36:21] |
| ACT_n | QAACT_n -> ACT_n : SDRAMs D[20:1] |
| QBACT_n | QBACT_n -> ACT_n : SDRAMs D[36:21] |
| C[2:0] | QAC[2:0] -> C[2:0] : SDRAMs D[20:1] |
| QBC[2:0] | QBC[2:0] -> C[2:0] : SDRAMs D[36:21] |
| PARITY | QAPAR -> PAR : SDRAMs D[20:1] |
| QBPAR | QBPAR -> PAR : SDRAMs D[36:21] |
| CKE0 | QACKE0 -> CKE : SDRAMs D[10:1] |
| QBCKE0 | QBCKE0 -> CKE : SDRAMs D[28:21] |
| CKE1 | QACKE1 -> CKE : SDRAMs D[20:11] |
| QBCKE1 | QBCKE1 -> CKE : SDRAMs D[36:29] |
| ODT0 | QAODT0 -> ODT : SDRAMs D[10:1] |
| QBODT0 | QBODT0 -> ODT : SDRAMs D[28:21] |
| ODT1 | QAODT1 -> ODT : SDRAMs D[20:11] |
| QBODT1 | QBODT1 -> ODT : SDRAMs D[36:29] |
| CS0_n | QACCS0_n -> CS_n : SDRAMs D[10:1] |
| QBCS0_n | QBCS0_n -> CS_n : SDRAMs D[28:21] |
| CS1_n | QACCS1_n -> CS_n : SDRAMs D[20:11] |
| QBCS1_n | QBCS1_n -> CS_n : SDRAMs D[36:29] |
| CK0_t | Y0_t -> CK_t : SDRAMs D[24:21], D[32:29] |
| Y1_t | Y1_t -> CK_t : SDRAMs D[5:1], D[15:11] |
| Y2_t | Y2_t -> CK_t : SDRAMs D[28:25], D[36:33] |
| Y3_t | Y3_t -> CK_t : SDRAMs D[10:6], D[20:16] |
| CK0_c | Y0_c -> CK_c : SDRAMs D[24:21], D[32:29] |
| Y1_c | Y1_c -> CK_c : SDRAMs D[5:1], D[15:11] |
| Y2_c | Y2_c -> CK_c : SDRAMs D[28:25], D[36:33] |
| Y3_c | Y3_c -> CK_c : SDRAMs D[10:6], D[20:16] |
| RESET_n | QRST_n -> RESET_n : All SDRAMs |
| ALERT_n | ERROR_IN_n -> ALERT_n : All SDRAMs |

- NOTE :**
1. CK0_t, CK0_c terminated with 120Ω ± 5% resistor.
 2. CK1_t, CK1_c terminated with 120Ω ± 5% resistor but not used.
 3. Unless otherwise noted resistors are 22Ω ± 5%.

10. Absolute Maximum Ratings

10.1 Absolute Maximum DC Ratings

[Table 2] Absolute Maximum DC Ratings

| Symbol | Parameter | Rating | Units | NOTE |
|------------------------------------|-----------------------------------------|-------------|-------|------|
| VDD | Voltage on VDD pin relative to Vss | -0.3 ~ 1.5 | V | 1,3 |
| VDDQ | Voltage on VDDQ pin relative to Vss | -0.3 ~ 1.5 | V | 1,3 |
| VPP | Voltage on VPP pin relative to Vss | -0.3 ~ 3.0 | V | 4 |
| V _{IN} , V _{OUT} | Voltage on any pin except VREFCA to Vss | -0.3 ~ 1.5 | V | 1,3 |
| T _{STG} | Storage Temperature | -55 to +100 | °C | 1,2 |

NOTE :

- Stresses greater than those listed under "Absolute Maximum Ratings" may cause permanent damage to the device. This is a stress rating only and functional operation of the device at these or any other conditions above those indicated in the operational sections of this specification is not implied. Exposure to absolute maximum rating conditions for extended periods may affect reliability
- Storage Temperature is the case surface temperature on the center/top side of the DRAM. For the measurement conditions, please refer to JESD51-2 standard.
- VDD and VDDQ must be within 300 mV of each other at all times; and VREFCA must be not greater than 0.6 x VDDQ, When VDD and VDDQ are less than 500 mV; VREFCA may be equal to or less than 300 mV
- VPP must be equal or greater than VDD/VDDQ at all times.

11. AC & DC Operating Conditions

11.1 Recommended DC Operating Conditions

[Table 3] Recommended DC Operating Conditions

| Symbol | Parameter | Rating | | | Unit | NOTE |
|--------|---------------------------|--------|------|------|------|-------|
| | | Min. | Typ. | Max. | | |
| VDD | Supply Voltage | 1.14 | 1.2 | 1.26 | V | 1,2,3 |
| VDDQ | Supply Voltage for Output | 1.14 | 1.2 | 1.26 | V | 1,2,3 |
| VPP | Peak-to-Peak Voltage | 2.375 | 2.5 | 2.75 | V | 3 |

NOTE:

- Under all conditions V_{DDQ} must be less than or equal to V_{DD}.
- V_{DDQ} tracks with V_{DD}. AC parameters are measured with V_{DD} and V_{DDQ} tied together.
- DC bandwidth is limited to 20MHz.

12. AC & DC Input Measurement Levels

12.1 AC & DC Logic Input Levels for Single-Ended Signals

[Table 4] Single-ended AC & DC Input Levels for Command and Address

| Symbol | Parameter | DDR4-1600/1866/2133/2400 | | Unit | NOTE |
|----------------------------|---------------------------------------|----------------------------|---------------------------|------|------|
| | | Min. | Max. | | |
| V _{IH,CA} (DC75) | DC input logic high | V _{REFCA} + 0.075 | V _{DD} | V | |
| V _{IL,CA} (DC75) | DC input logic low | V _{SS} | V _{REFCA} -0.075 | V | |
| V _{IH,CA} (AC100) | AC input logic high | V _{REF} + 0.1 | Note 2 | V | 1 |
| V _{IL,CA} (AC100) | AC input logic low | Note 2 | V _{REF} - 0.1 | V | 1 |
| V _{REFCA} (DC) | Reference Voltage for ADD, CMD inputs | 0.49*V _{DD} | 0.51*V _{DD} | V | 2,3 |

- NOTE :**
1. See "Overshoot and Undershoot Specifications" on section.
 2. The AC peak noise on V_{REFCA} may not allow V_{REFCA} to deviate from V_{REFCA}(DC) by more than ± 1% V_{DD} (for reference : approx. ± 12mV)
 3. For reference : approx. V_{DD}/2 ± 12mV

12.2 AC and DC Input Measurement Levels : V_{REF} Tolerances.

The DC-tolerance limits and ac-noise limits for the reference voltages V_{REFCA} is illustrated in Figure 1. It shows a valid reference voltage V_{REF}(t) as a function of time. (V_{REF} stands for V_{REFCA}).

V_{REF}(DC) is the linear average of V_{REF}(t) over a very long period of time (e.g. 1 sec). This average has to meet the min/max requirement in Table X. Furthermore V_{REF}(t) may temporarily deviate from V_{REF}(DC) by no more than ± 1% V_{DD}.

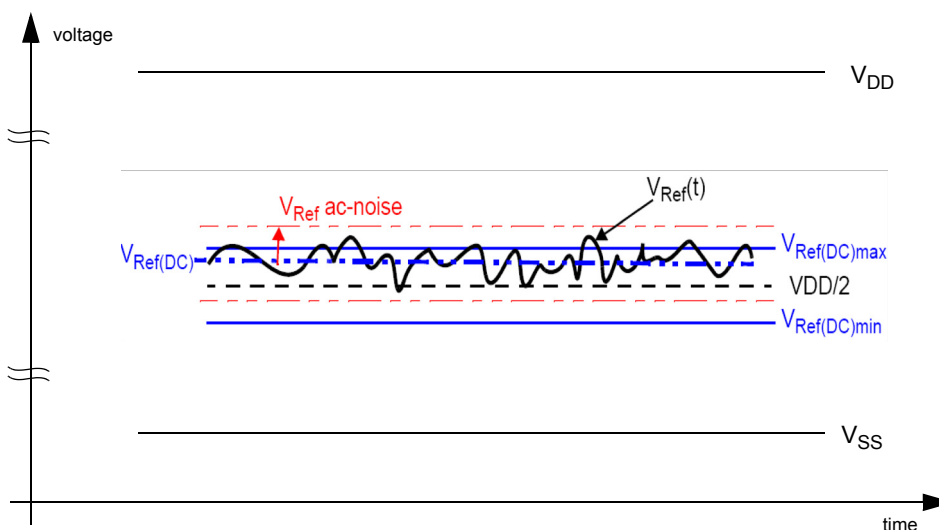

Figure 1. Illustration of V_{REF}(DC) tolerance and V_{REF} AC-noise limits

The voltage levels for setup and hold time measurements V_{IH}(AC), V_{IH}(DC), V_{IL}(AC) and V_{IL}(DC) are dependent on V_{REF}.

"V_{REF}" shall be understood as V_{REF}(DC), as defined in Figure 1.

This clarifies, that DC-variations of V_{REF} affect the absolute voltage a signal has to reach to achieve a valid high or low level and therefore the time to which setup and hold is measured. System timing and voltage budgets need to account for V_{REF}(DC) deviations from the optimum position within the data-eye of the input signals.

This also clarifies that the DRAM setup/hold specification and derating values need to include time and voltage associated with V_{REF} AC-noise. Timing and voltage effects due to AC-noise on V_{REF} up to the specified limit (+/-1% of V_{DD}) are included in DRAM timings and their associated deratings.

12.3 AC and DC Logic Input Levels for Differential Signals

12.3.1 Differential Signals Definition

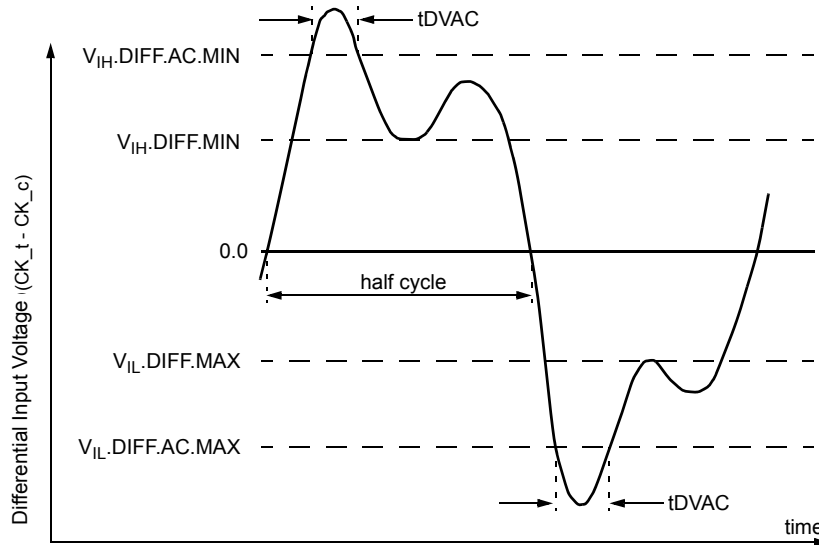

Figure 2. Definition of differential ac-swing and “time above ac-level” tDVAC

NOTE :

1. Differential signal rising edge from V_{IL,DIFF.MAX} to V_{IH,DIFF.MIN} must be monotonic slope.
2. Differential signal falling edge from V_{IH,DIFF.MIN} to V_{IL,DIFF.MAX} must be monotonic slope.

12.3.2 Differential Swing Requirements for Clock (CK_t - CK_c)

[Table 5] Differential AC and DC Input Levels

| Symbol | Parameter | DDR4 -1600/1866/2133 | | DDR4 -2400 | | unit | NOTE |
|-------------------------|----------------------------|-----------------------------------------------|-----------------------------------------------|-----------------------------------------------|-----------------------------------------------|------|------|
| | | min | max | min | max | | |
| V _{IHdiff} | differential input high | +0.150 | NOTE 3 | TBD | NOTE 3 | V | 1 |
| V _{ILdiff} | differential input low | NOTE 3 | -0.150 | NOTE 3 | TBD | V | 1 |
| V _{IHdiff(AC)} | differential input high ac | 2 x (V _{IH(AC)} - V _{REF}) | NOTE 3 | 2 x (V _{IH(AC)} - V _{REF}) | NOTE 3 | V | 2 |
| V _{ILdiff(AC)} | differential input low ac | NOTE 3 | 2 x (V _{IL(AC)} - V _{REF}) | NOTE 3 | 2 x (V _{IL(AC)} - V _{REF}) | V | 2 |

NOTE:

1. Used to define a differential signal slew-rate.
2. for CK_t - CK_c use V_{IH,CA}/V_{IL,CA(AC)} of ADD/CMD and V_{REFCA};
3. These values are not defined; however, the differential signals CK_t - CK_c, need to be within the respective limits (V_{IH,CA}(DC) max, V_{IL,CA}(DC)min) for single-ended signals as well as the limitations for overshoot and undershoot.

[Table 6] Allowed Time Before Ringback (tDVAC) for CK_t - CK_c

| Slew Rate [V/ns] | tDVAC [ps] @ V _{IH/Ldiff(AC)} = 200mV | |
|------------------|---------------------------------------------------|-----|
| | min | max |
| > 4.0 | 120 | - |
| 4.0 | 115 | - |
| 3.0 | 110 | - |
| 2.0 | 105 | - |
| 1.8 | 100 | - |
| 1.6 | 95 | - |
| 1.4 | 90 | - |
| 1.2 | 85 | - |
| 1.0 | 80 | - |
| < 1.0 | 80 | - |

12.3.3 Single-ended Requirements for Differential Signals

Each individual component of a differential signal (CK_t, CK_c) has also to comply with certain requirements for single-ended signals.

CK_t and CK_c have to approximately reach VSEHmin / VSELmax (approximately equal to the ac-levels (VIH.CA(AC) / VIL.CA(AC)) for ADD/CMD signals) in every half-cycle.

Note that the applicable ac-levels for ADD/CMD might be different per speed-bin etc. E.g., if Different value than VIH.CA(AC100)/VIL.CA(AC100) is used for ADD/CMD signals, then these ac-levels apply also for the single-ended signals CK_t and CK_c

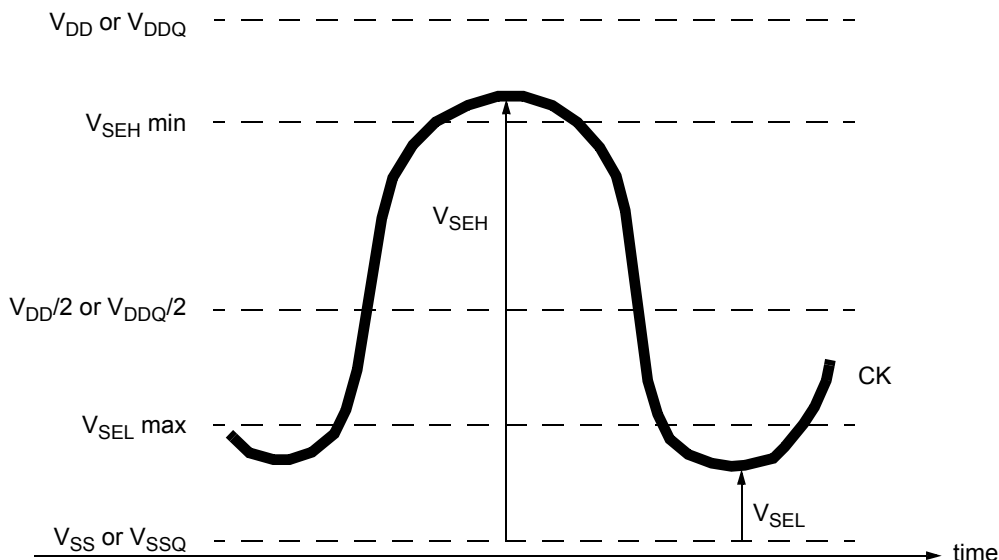

Figure 3. Single-ended requirement for differential signals.

Note that, while ADD/CMD signal requirements are with respect to VrefCA, the single-ended components of differential signals have a requirement with respect to VDD / 2; this is nominally the same. The transition of single-ended signals through the ac-levels is used to measure setup time. For single-ended components of differential signals the requirement to reach VSELmax, VSEHmin has no bearing on timing, but adds a restriction on the common mode characteristics of these signals.

[Table 7] Single-ended Levels for CK_t, CK_c

| Symbol | Parameter | DDR4-1600/1866/2133 | | DDR4-2400 | | Unit | NOTE |
|--------|----------------------------------------|---------------------|---------------|-----------|-------|------|------|
| | | Min | Max | Min | Max | | |
| VSEH | Single-ended high-level for CK_t, CK_c | (VDD/2)+0.100 | NOTE3 | TBD | NOTE3 | V | 1, 2 |
| VSEL | Single-ended low-level for CK_t, CK_c | NOTE3 | (VDD/2)-0.100 | NOTE3 | TBD | V | 1, 2 |

- NOTE :**
1. For CK_t - CK_c use VIH,CA/VIL,CA(AC) of ADD/CMD;
 2. VIH(AC)/VIL(AC) for ADD/CMD is based on VREFCA;
 3. These values are not defined, however the single-ended signals CK_t - CK_c need to be within the respective limits (VIH,CA(DC) max, VIL,CA(DC)min) for single-ended signals as well as the limitations for overshoot and undershoot.

12.4 Slew Rate Definitions

12.4.1 Slew Rate Definitions for Differential Input Signals (CK)

[Table 8] Differential Input Slew Rate Definition

| Description | | | Defined by |
|------------------------------------------------------------|-----------------|-----------------|-----------------------------------------------------|
| | from | to | |
| Differential input slew rate for rising edge(CK_t - CK_c) | $V_{ILdiffmax}$ | $V_{IHdiffmin}$ | $[V_{IHdiffmin} - V_{ILdiffmax}] / \Delta TRdiff$ |
| Differential input slew rate for falling edge(CK_t - CK_c) | $V_{IHdiffmin}$ | $V_{ILdiffmax}$ | $[V_{IHdiffmin} - V_{ILdiffmax}] / \Delta TFdiff$ |

NOTE: The differential signal (i.e.,CK_t - CK_c) must be linear between these thresholds.

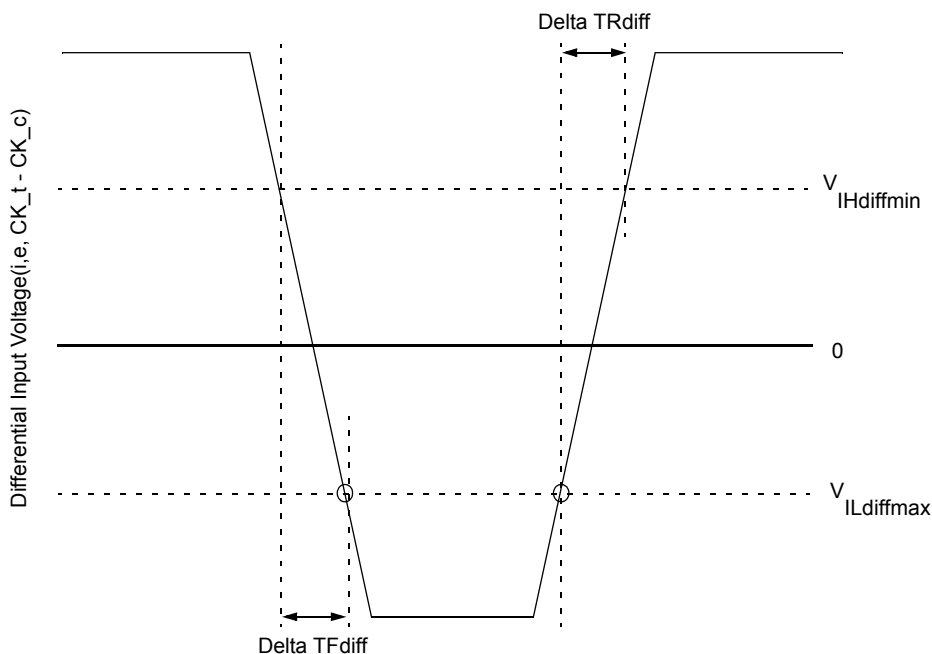

Figure 4. Differential Input Slew Rate Definition for CK_t, CK_c

12.5 Differential Input Cross Point Voltage

To guarantee tight setup and hold times as well as output skew parameters with respect to clock, each cross point voltage of differential input signals (CK_t, CK_c) must meet the requirements in Table. The differential input cross point voltage VIX is measured from the actual cross point of true and complement signals to the midlevel between of VDD and VSS.

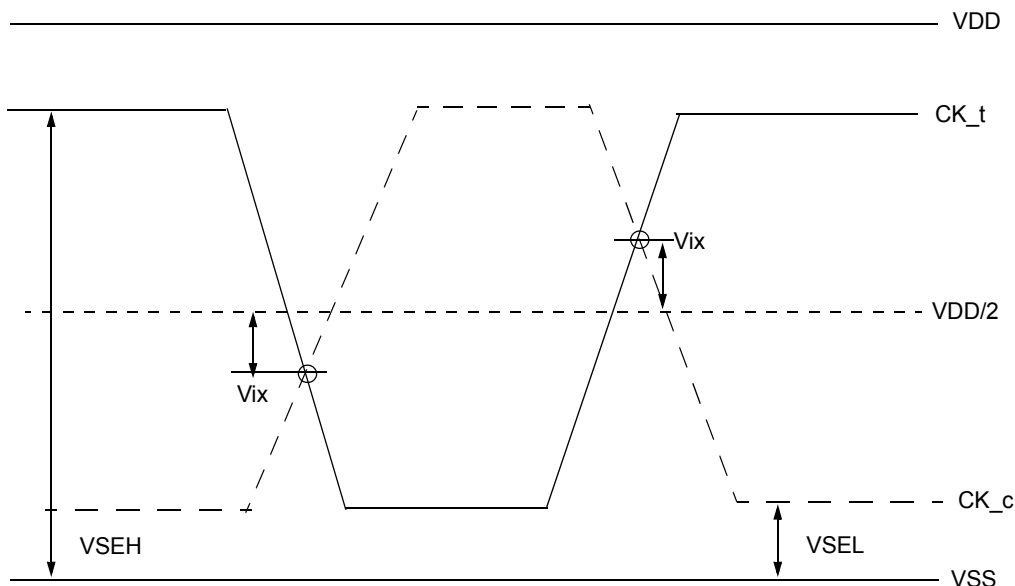

Figure 5. Vix Definition (CK)

[Table 9] Cross Point Voltage for Differential Input Signals (CK)

| Symbol | Parameter | DDR4-1600/1866/2133 | | | |
|---------|------------------------------------------------------------------------------------------------|----------------------|--------------------------------------|--------------------------------------|----------------------|
| | | min | | max | |
| - | Area of VSEH, VSEL | VSEL ≤ VDD/2 - 145mV | VDD/2 - 145mV ≤ VSEL ≤ VDD/2 - 100mV | VDD/2 + 100mV ≤ VSEH ≤ VDD/2 + 145mV | VDD/2 + 145mV ≤ VSEH |
| VIX(CK) | Differential Input Cross Point Voltage relative to VDD/2 for CK _t , CK _c | -120mV | -(VDD/2 - VSEL) + 25mV | (VSEH - VDD/2) - 25mV | 120mV |

| Symbol | Parameter | DDR4-2400 | | | |
|---------|------------------------------------------------------------------------------------------------|-----------|-----|-----|-----|
| | | min | | max | |
| - | Area of VSEH, VSEL | TBD | TBD | TBD | TBD |
| VIX(CK) | Differential Input Cross Point Voltage relative to VDD/2 for CK _t , CK _c | TBD | TBD | TBD | TBD |

12.6 Single-ended AC & DC Output Levels

[Table 10] Single-ended AC & DC Output Levels

| Symbol | Parameter | DDR4-1600/1866/2133/2400 | Units | NOTE |
|----------------------|-----------------------------------------------------------|---------------------------------|-------|------|
| V _{OH} (DC) | DC output high measurement level (for IV curve linearity) | 1.1 x V _{DDQ} | V | |
| V _{OM} (DC) | DC output mid measurement level (for IV curve linearity) | 0.8 x V _{DDQ} | V | |
| V _{OL} (DC) | DC output low measurement level (for IV curve linearity) | 0.5 x V _{DDQ} | V | |
| V _{OH} (AC) | AC output high measurement level (for output SR) | (0.7 + 0.15) x V _{DDQ} | V | 1 |
| V _{OL} (AC) | AC output low measurement level (for output SR) | (0.7 - 0.15) x V _{DDQ} | V | 1 |

NOTE :
 1. The swing of $\pm 0.15 \times V_{DDQ}$ is based on approximately 50% of the static single-ended output peak-to-peak swing with a driver impedance of RZQ/7Ω and an effective test load of 50Ω to V_{TT} = V_{DDQ}.

12.7 Differential AC & DC Output Levels

[Table 11] Differential AC & DC Output Levels

| Symbol | Parameter | DDR4-1600/1866/2133/2400 | Units | NOTE |
|--------------------------|---------------------------------------------------------------|--------------------------|-------|------|
| V _{OHdiff} (AC) | AC differential output high measurement level (for output SR) | +0.3 x V _{DDQ} | V | 1 |
| V _{OLdiff} (AC) | AC differential output low measurement level (for output SR) | -0.3 x V _{DDQ} | V | 1 |

NOTE :
 1. The swing of $\pm 0.3 \times V_{DDQ}$ is based on approximately 50% of the static differential output peak-to-peak swing with a driver impedance of RZQ/7Ω and an effective test load of 50Ω to V_{TT} = V_{DDQ} at each of the differential outputs.

12.8 Single-ended Output Slew Rate

With the reference load for timing measurements, output slew rate for falling and rising edges is defined and measured between V_{OL}(AC) and V_{OH}(AC) for single ended signals as shown in Table 12 and Figure 6.

[Table 12] Single-ended Output Slew Rate Definition

| Description | Measured | | Defined by |
|------------------------------------------------|----------------------|----------------------|----------------------------------------------------------|
| | From | To | |
| Single ended output slew rate for rising edge | V _{OL} (AC) | V _{OH} (AC) | [V _{OH} (AC)-V _{OL} (AC)] / Delta TRse |
| Single ended output slew rate for falling edge | V _{OH} (AC) | V _{OL} (AC) | [V _{OH} (AC)-V _{OL} (AC)] / Delta TFse |

NOTE :
 1. Output slew rate is verified by design and characterization, and may not be subject to production test.

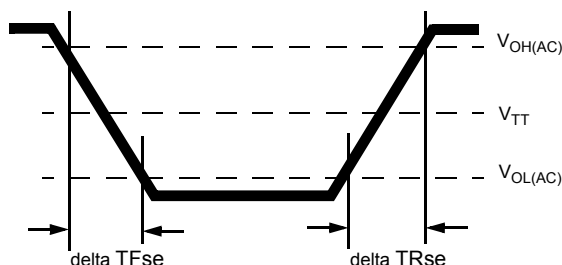

Figure 6. Single-ended Output Slew Rate Definition

[Table 13] Single-ended Output Slew Rate

| Parameter | Symbol | DDR4-1600 | | DDR4-1866 | | DDR4-2133 | | DDR4-2400 | | Units |
|-------------------------------|--------|-----------|-----|-----------|-----|-----------|-----|-----------|-----|-------|
| | | Min | Max | Min | Max | Min | Max | Min | Max | |
| Single ended output slew rate | SRQse | 4 | 9 | 4 | 9 | 4 | 9 | 4 | 9 | V/ns |

Description: SR: Slew Rate

Q: Query Output (like in DQ, which stands for Data-in, Query-Output)

se: Single-ended Signals

For Ron = RZQ/7 setting

NOTE :

1. In two cases, a maximum slew rate of 12 V/ns applies for a single DQ signal within a byte lane.

-Case 1 is defined for a single DQ signal within a byte lane which is switching into a certain direction (either from high to low or low to high) while all remaining DQ signals in the same byte lane are static (i.e. they stay at either high or low).

-Case 2 is defined for a single DQ signal within a byte lane which is switching into a certain direction (either from high to low or low to high) while all remaining DQ signals in the same byte lane are switching into the opposite direction (i.e. from low to high or high to low respectively). For the remaining DQ signal switching into the opposite direction, the regular maximum limit of 9 V/ns applies

12.9 Differential Output Slew Rate

With the reference load for timing measurements, output slew rate for falling and rising edges is defined and measured between VOLdiff(AC) and VOHdiff(AC) for differential signals as shown in Table 14 and Figure 7.

[Table 14] Differential Output Slew Rate Definition

| Description | Measured | | Defined by |
|------------------------------------------------|-------------------------|-------------------------|--------------------------------------------------------|
| | From | To | |
| Differential output slew rate for rising edge | V _{OLdiff(AC)} | V _{OHdiff(AC)} | $[V_{OHdiff(AC)} - V_{OLdiff(AC)}] / \Delta TR_{diff}$ |
| Differential output slew rate for falling edge | V _{OHdiff(AC)} | V _{OLdiff(AC)} | $[V_{OHdiff(AC)} - V_{OLdiff(AC)}] / \Delta TF_{diff}$ |

NOTE :

1. Output slew rate is verified by design and characterization, and may not be subject to production test.

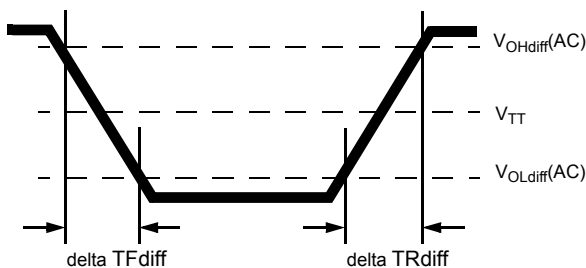

Figure 7. Differential Output Slew Rate Definition

[Table 15] Differential Output Slew Rate

| Parameter | Symbol | DDR4-1600 | | DDR4-1866 | | DDR4-2133 | | DDR4-2400 | | Units |
|-------------------------------|---------|-----------|-----|-----------|-----|-----------|-----|-----------|-----|-------|
| | | Min | Max | Min | Max | Min | Max | Min | Max | |
| Differential output slew rate | SRQdiff | 8 | 18 | 8 | 18 | 8 | 18 | 8 | 18 | V/ns |

Description:

SR: Slew Rate

Q: Query Output (like in DQ, which stands for Data-in, Query-Output)

diff: Differential Signals

For Ron = RZQ/7 setting

12.10 Single-ended AC & DC Output Levels of Connectivity Test Mode

Following output parameters will be applied for DDR4 SDRAM Output Signal during Connectivity Test Mode.

[Table 16] Single-ended AC & DC Output Levels of Connectivity Test Mode

| Symbol | Parameter | DDR4-1600/1866/2133/2400 | Unit | Notes |
|--------------|------------------------------------------------------------|---------------------------------|------|-------|
| $V_{OH(DC)}$ | DC output high measurement level (for IV curve linearity) | $1.1 \times V_{DDQ}$ | V | |
| $V_{OM(DC)}$ | DC output mid measurement level (for IV curve linearity) | $0.8 \times V_{DDQ}$ | V | |
| $V_{OL(DC)}$ | DC output low measurement level (for IV curve linearity) | $0.5 \times V_{DDQ}$ | V | |
| $V_{OB(DC)}$ | DC output below measurement level (for IV curve linearity) | $0.2 \times V_{DDQ}$ | V | |
| $V_{OH(AC)}$ | AC output high measurement level (for output SR) | $V_{TT} + (0.1 \times V_{DDQ})$ | V | 1 |
| $V_{OL(AC)}$ | AC output below measurement level (for output SR) | $V_{TT} - (0.1 \times V_{DDQ})$ | V | 1 |

NOTE :

1. The effective test load is 50Ω terminated by $V_{TT} = 0.5 \times V_{DDQ}$.

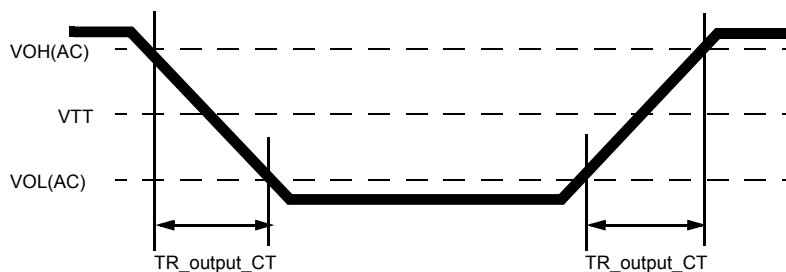

Figure 8. Output Slew Rate Definition of Connectivity Test Mode

[Table 17] Single-ended Output Slew Rate of Connectivity Test Mode

| Parameter | Symbol | DDR4-1600/1866/2133/2400 | | Unit | Notes |
|----------------------------|--------------|--------------------------|-----|------|-------|
| | | Min | Max | | |
| Output signal Falling time | TF_output_CT | - | 10 | ns/V | |
| Output signal Rising time | TR_output_CT | - | 10 | ns/V | |

12.11 Test Load for Connectivity Test Mode Timing

The reference load for ODT timings is defined in Figure 7.

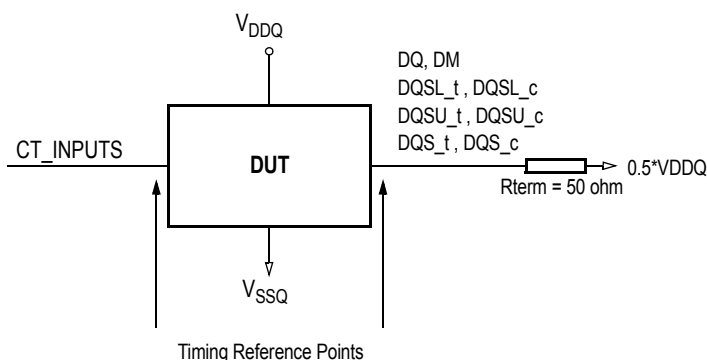

Figure 9. Connectivity Test Mode Timing Reference Load

13. DIMM IDD Specification Definition

[Table 18] Basic IDD, IPP and IDDQ Measurement Conditions

| Symbol | Description |
|--------------------|-------------------------------------------------------------------------------------------------------------------------------------------------------------------------------------------------------------------------------------------------------------------------------------------------------------------------------------------------------------------------------------------------------------------------------------------------------------------------------------------------------------------------------------------------------------------------------------------------------------------------------------------------------------------------------|
| IDD0 | Operating One Bank Active-Precharge Current (AL=0) CKE: High; External clock: On; tCK, nRC, nRAS, CL: Refer to Component Datasheet for detail pattern; BL: 8 ¹ ; AL: 0; CS_n: High between ACT and PRE; Command, Address, Bank Group Address, Bank Address Inputs: partially toggling; Data IO: VDDQ; DM_n: stable at 1; Bank Activity: Cycling with one bank active at a time: 0,0,1,1,2,2,... ; Output Buffer and RTT: Enabled in Mode Registers ² ; ODT Signal: stable at 0; Pattern Details: Refer to Component Datasheet for detail pattern |
| IDD0A | Operating One Bank Active-Precharge Current (AL=CL-1) AL = CL-1, Other conditions: see IDD0 |
| IPP0 | Operating One Bank Active-Precharge IPP Current Same condition with IDD0 |
| IDD1 | Operating One Bank Active-Read-Precharge Current (AL=0) CKE: High; External clock: On; tCK, nRC, nRAS, nRCD, CL: Refer to Component Datasheet for detail pattern; BL: 8 ¹ ; AL: 0; CS_n: High between ACT, RD and PRE; Command, Address, Bank Group Address, Bank Address Inputs, Data IO: partially toggling; DM_n: stable at 1; Bank Activity: Cycling with one bank active at a time: 0,0,1,1,2,2,... ; Output Buffer and RTT: Enabled in Mode Registers ² ; ODT Signal: stable at 0; Pattern Details: Refer to Component Datasheet for detail pattern |
| IDD1A | Operating One Bank Active-Read-Precharge Current (AL=CL-1) AL = CL-1, Other conditions: see IDD1 |
| IPP1 | Operating One Bank Active-Read-Precharge IPP Current Same condition with IDD1 |
| IDD2N | Precharge Standby Current (AL=0) CKE: High; External clock: On; tCK, CL: Refer to Component Datasheet for detail pattern; BL: 8 ¹ ; AL: 0; CS_n: stable at 1; Command, Address, Bank Group Address, Bank Address Inputs: partially toggling ; Data IO: VDDQ; DM_n: stable at 1; Bank Activity: all banks closed; Output Buffer and RTT: Enabled in Mode Registers ² ; ODT Signal: stable at 0; Pattern Details: Refer to Component Datasheet for detail pattern |
| IDD2NA | Precharge Standby Current (AL=CL-1) AL = CL-1, Other conditions: see IDD2N |
| IPP2N | Precharge Standby IPP Current Same condition with IDD2N |
| IDD2NT | Precharge Standby ODT Current CKE: High; External clock: On; tCK, CL: Refer to Component Datasheet for detail pattern; BL: 8 ¹ ; AL: 0; CS_n: stable at 1; Command, Address, Bank Group Address, Bank Address Inputs: partially toggling ; Data IO: VSSQ; DM_n: stable at 1; Bank Activity: all banks closed; Output Buffer and RTT: Enabled in Mode Registers ² ; ODT Signal: toggling according ; Pattern Details: Refer to Component Datasheet for detail pattern |
| IDDQ2NT (Optional) | Precharge Standby ODT IDDQ Current Same definition like for IDD2NT, however measuring IDDQ current instead of IDD current |
| IDD2NL | Precharge Standby Current with CAL enabled Same definition like for IDD2N, CAL enabled ³ |
| IDD2NG | Precharge Standby Current with Gear Down mode enabled Same definition like for IDD2N, Gear Down mode enabled ^{3,5} |
| IDD2ND | Precharge Standby Current with DLL disabled Same definition like for IDD2N, DLL disabled ³ |
| IDD2N_par | Precharge Standby Current with CA parity enabled Same definition like for IDD2N, CA parity enabled ³ |
| IDD2P | Precharge Power-Down Current CKE: Low; External clock: On; tCK, CL: Refer to Component Datasheet for detail pattern; BL: 8 ¹ ; AL: 0; CS_n: stable at 1; Command, Address, Bank Group Address, Bank Address Inputs: stable at 0; Data IO: VDDQ; DM_n: stable at 1; Bank Activity: all banks closed; Output Buffer and RTT: Enabled in Mode Registers ² ; ODT Signal: stable at 0 |
| IPP2P | Precharge Power-Down IPP Current Same condition with IDD2P |
| IDD2Q | Precharge Quiet Standby Current CKE: High; External clock: On; tCK, CL: Refer to Component Datasheet for detail pattern; BL: 8 ¹ ; AL: 0; CS_n: stable at 1; Command, Address, Bank Group Address, Bank Address Inputs: stable at 0; Data IO: VDDQ; DM_n: stable at 1; Bank Activity: all banks closed; Output Buffer and RTT: Enabled in Mode Registers ² ; ODT Signal: stable at 0 |

| Symbol | Description |
|--------------------|---------------------------------------------------------------------------------------------------------------------------------------------------------------------------------------------------------------------------------------------------------------------------------------------------------------------------------------------------------------------------------------------------------------------------------------------------------------------------------------------------------------------------------------------------------------------------------------------------------------------------------------|
| IDD3N | Active Standby Current CKE: High; External clock: On; tCK, CL: Refer to Component Datasheet for detail pattern; BL: 8 ¹ ; AL: 0; CS_n: stable at 1; Command, Address, Bank Group Address, Bank Address Inputs: partially toggling; Data IO: VDDQ; DM_n: stable at 1; Bank Activity: all banks open; Output Buffer and RTT: Enabled in Mode Registers ² ; ODT Signal: stable at 0; Pattern Details: Refer to Component Datasheet for detail pattern |
| IDD3NA | Active Standby Current (AL=CL-1) AL = CL-1, Other conditions: see IDD3N |
| IPP3N | Active Standby IPP Current Same condition with IDD3N |
| IDD3P | Active Power-Down Current CKE: Low; External clock: On; tCK, CL: Refer to Component Datasheet for detail pattern; BL: 8 ¹ ; AL: 0; CS_n: stable at 1; Command, Address, Bank Group Address, Bank Address Inputs: stable at 0; Data IO: VDDQ; DM_n: stable at 1; Bank Activity: all banks open; Output Buffer and RTT: Enabled in Mode Registers ² ; ODT Signal: stable at 0 |
| IPP3P | Active Power-Down IPP Current Same condition with IDD3P |
| IDD4R | Operating Burst Read Current CKE: High; External clock: On; tCK, CL: Refer to Component Datasheet for detail pattern; BL: 8 ² ; AL: 0; CS_n: High between RD; Command, Address, Bank Group Address, Bank Address Inputs: partially toggling; Data IO: seamless read data burst with different data between one burst and the next one according; DM_n: stable at 1; Bank Activity: all banks open, RD commands cycling through banks: 0,0,1,1,2,2,...; Output Buffer and RTT: Enabled in Mode Registers ² ; ODT Signal: stable at 0; Pattern Details: Refer to Component Datasheet for detail pattern |
| IDD4RA | Operating Burst Read Current (AL=CL-1) AL = CL-1, Other conditions: see IDD4R |
| IDD4RB | Operating Burst Read Current with Read DBI Read DBI enabled ³ , Other conditions: see IDD4R |
| IPP4R | Operating Burst Read IPP Current Same condition with IDD4R |
| IDDQ4R (Optional) | Operating Burst Read IDDQ Current Same definition like for IDD4R, however measuring IDDQ current instead of IDD current |
| IDDQ4RB (Optional) | Operating Burst Read IDDQ Current with Read DBI Same definition like for IDD4RB, however measuring IDDQ current instead of IDD current |
| IDD4W | Operating Burst Write Current CKE: High; External clock: On; tCK, CL: Refer to Component Datasheet for detail pattern; BL: 8 ¹ ; AL: 0; CS_n: High between WR; Command, Address, Bank Group Address, Bank Address Inputs: partially toggling; Data IO: seamless write data burst with different data between one burst and the next one; DM_n: stable at 1; Bank Activity: all banks open, WR commands cycling through banks: 0,0,1,1,2,2,...; Output Buffer and RTT: Enabled in Mode Registers ² ; ODT Signal: stable at HIGH; Pattern Details: Refer to Component Datasheet for detail pattern |
| IDD4WA | Operating Burst Write Current (AL=CL-1) AL = CL-1, Other conditions: see IDD4W |
| IDD4WB | Operating Burst Write Current with Write DBI Write DBI enabled ³ , Other conditions: see IDD4W |
| IDD4WC | Operating Burst Write Current with Write CRC Write CRC enabled ³ , Other conditions: see IDD4W |
| IDD4W_par | Operating Burst Write Current with CA Parity CA Parity enabled ³ , Other conditions: see IDD4W |
| IPP4W | Operating Burst Write IPP Current Same condition with IDD4W |
| IDD5B | Burst Refresh Current (1X REF) CKE: High; External clock: On; tCK, CL, nRFC: Refer to Component Datasheet for detail pattern; BL: 8 ¹ ; AL: 0; CS_n: High between REF; Command, Address, Bank Group Address, Bank Address Inputs: partially toggling; Data IO: VDDQ; DM_n: stable at 1; Bank Activity: REF command every nRFC; Output Buffer and RTT: Enabled in Mode Registers ² ; ODT Signal: stable at 0; Pattern Details: Refer to Component Datasheet for detail pattern |
| IPP5B | Burst Refresh Write IPP Current (1X REF) Same condition with IDD5B |
| IDD5F2 | Burst Refresh Current (2X REF) tRFC=tRFC_x2, Other conditions: see IDD5B |
| IPP5F2 | Burst Refresh Write IPP Current (2X REF) Same condition with IDD5F2 |

14. IDD SPEC Table

IDD and IPP values are for full operating range of voltage and temperature unless otherwise noted. IDD and IPP values are for full operating range of voltage and temperature unless otherwise noted.

[Table 19] I_{DD} and I_{DDQ} Specification

| Symbol | 16GB(2Gx72) Module | | | | 32GB(4Gx72) Module | | | | Unit | NOTE |
|-----------------|--------------------|----------|--------------|----------|--------------------|----------|--------------|----------|------|------|
| | M393A2K40BB0 | | M393A2K40BB1 | | M393A4K40BB0 | | M393A4K40BB1 | | | |
| | DDR4-2133 | | DDR4-2400 | | DDR4-2133 | | DDR4-2400 | | | |
| | 15-15-15 | | 17-17-17 | | 15-15-15 | | 17-17-17 | | | |
| | 1.2V | | 1.2V | | 1.2V | | 1.2V | | | |
| | IDD Max. | IPP Max. | IDD Max. | IPP Max. | IDD Max. | IPP Max. | IDD Max. | IPP Max. | | |
| I_{DD0} | 1290 | 72 | 1310 | 72 | 1700 | 126 | 1750 | 126 | mA | |
| I_{DD0A} | 1330 | 72 | 1370 | 72 | 1750 | 126 | 1810 | 126 | mA | |
| I_{DD1} | 1550 | 72 | 1600 | 72 | 1970 | 126 | 2040 | 126 | mA | |
| I_{DD1A} | 1590 | 72 | 1650 | 72 | 2010 | 126 | 2090 | 126 | mA | |
| I_{DD2N} | 1130 | 54 | 1150 | 54 | 1550 | 108 | 1590 | 108 | mA | |
| I_{DD2NA} | 1180 | 54 | 1210 | 54 | 1600 | 108 | 1650 | 108 | mA | |
| I_{DD2NT} | 1180 | 54 | 1210 | 54 | 1600 | 108 | 1650 | 108 | mA | |
| I_{DD2NL} | 1020 | 54 | 1050 | 54 | 1440 | 108 | 1480 | 108 | mA | |
| I_{DD2NG} | 1130 | 54 | 1150 | 54 | 1550 | 108 | 1590 | 108 | mA | |
| I_{DD2ND} | 1090 | 54 | 1120 | 54 | 1510 | 108 | 1560 | 108 | mA | |
| I_{DD2N_par} | 1140 | 54 | 1170 | 54 | 1560 | 108 | 1610 | 108 | mA | |
| I_{DD2P} | 570 | 54 | 580 | 54 | 870 | 108 | 870 | 108 | mA | |
| I_{DD2Q} | 1090 | 54 | 1120 | 54 | 1490 | 108 | 1560 | 108 | mA | |
| I_{DD3N} | 1300 | 54 | 1310 | 54 | 1710 | 108 | 1740 | 108 | mA | |
| I_{DD3NA} | 1350 | 54 | 1360 | 54 | 1770 | 108 | 1800 | 108 | mA | |
| I_{DD3P} | 660 | 54 | 690 | 54 | 1050 | 108 | 1090 | 108 | mA | |
| I_{DD4R} | 2360 | 54 | 2530 | 54 | 2780 | 108 | 2970 | 108 | mA | |
| I_{DD4RA} | 2410 | 54 | 2590 | 54 | 2830 | 108 | 3030 | 108 | mA | |
| I_{DD4RB} | 2370 | 54 | 2540 | 54 | 2790 | 108 | 2970 | 108 | mA | |
| I_{DD4W} | 2260 | 54 | 2370 | 54 | 2690 | 108 | 2810 | 108 | mA | |
| I_{DD4WA} | 2340 | 54 | 2460 | 54 | 2760 | 108 | 2900 | 108 | mA | |
| I_{DD4WB} | 2260 | 54 | 2370 | 54 | 2690 | 108 | 2810 | 108 | mA | |
| I_{DD4WC} | 2080 | 54 | 2130 | 54 | 2500 | 108 | 2570 | 108 | mA | |
| I_{DD4W_par} | 2410 | 54 | 2540 | 54 | 2830 | 108 | 2980 | 108 | mA | |
| I_{DD5B} | 4590 | 324 | 4600 | 324 | 5010 | 378 | 5040 | 378 | mA | |
| I_{DD5F2} | 3430 | 270 | 3460 | 270 | 3850 | 324 | 3900 | 324 | mA | |
| I_{DD5F4} | 2990 | 252 | 3030 | 252 | 3410 | 306 | 3470 | 306 | mA | |
| I_{DD6N} | 440 | 72 | 440 | 72 | 860 | 144 | 860 | 144 | mA | |
| I_{DD6E} | 640 | 90 | 640 | 90 | 1250 | 180 | 1250 | 180 | mA | |
| I_{DD6R} | 310 | 63 | 320 | 63 | 610 | 126 | 610 | 126 | mA | |
| I_{DD6A} | 420 | 72 | 420 | 72 | 820 | 144 | 820 | 144 | mA | |
| I_{DD7} | 4570 | 144 | 5020 | 153 | 4990 | 198 | 5460 | 207 | mA | |
| I_{DD8} | 220 | 54 | 230 | 54 | 430 | 108 | 430 | 108 | mA | |

NOTE :

- DIMM IDD SPEC is based on the condition that de-activated rank(IDLE) is IDD2N. Please refer to Table 20.
- IDD current measure method and detail patterns are described on DDR4 component datasheet.
- VDD and VDDQ are merged on module PCB.
- DIMM IDD SPEC is measured with Qoff condition. (IDDQ values are not considered)

[Table 20] DIMM Rank Status

| SEC DIMM | Operating Rank | The other Rank |
|--------------------------|--------------------------|--------------------------|
| <i>I</i> _{DD0} | <i>I</i> _{DD0} | <i>I</i> _{DD2N} |
| <i>I</i> _{DD1} | <i>I</i> _{DD1} | <i>I</i> _{DD2N} |
| <i>I</i> _{DD2P} | <i>I</i> _{DD2P} | <i>I</i> _{DD2P} |
| <i>I</i> _{DD2N} | <i>I</i> _{DD2N} | <i>I</i> _{DD2N} |
| <i>I</i> _{DD2Q} | <i>I</i> _{DD2Q} | <i>I</i> _{DD2Q} |
| <i>I</i> _{DD3P} | <i>I</i> _{DD3P} | <i>I</i> _{DD3P} |
| <i>I</i> _{DD3N} | <i>I</i> _{DD3N} | <i>I</i> _{DD3N} |
| <i>I</i> _{DD4R} | <i>I</i> _{DD4R} | <i>I</i> _{DD2N} |
| <i>I</i> _{DD4W} | <i>I</i> _{DD4W} | <i>I</i> _{DD2N} |
| <i>I</i> _{DD5B} | <i>I</i> _{DD5B} | <i>I</i> _{DD2N} |
| <i>I</i> _{DD6} | <i>I</i> _{DD6} | <i>I</i> _{DD6} |
| <i>I</i> _{DD7} | <i>I</i> _{DD7} | <i>I</i> _{DD2N} |
| <i>I</i> _{DD8} | <i>I</i> _{DD8} | <i>I</i> _{DD8} |

15. Input/Output Capacitance

[Table 21] Silicon Pad I/O Capacitance

| Symbol | Parameter | DDR4-1600/1866/2133 | | DDR4-2400 | | Unit | NOTE |
|-------------------------|----------------------------------------------------------------------|---------------------|------|-----------|------|------|----------|
| | | min | max | min | max | | |
| C _{IO} | Input/output capacitance | 0.55 | 1.4 | 0.55 | 1.15 | pF | 1,2,3 |
| C _{DIO} | Input/output capacitance delta | -0.1 | 0.1 | -0.1 | 0.1 | pF | 1,2,3,11 |
| C _{DDQS} | Input/output capacitance delta DQS _t and DQS _c | - | 0.05 | - | 0.05 | pF | 1,2,3,5 |
| C _{CK} | Input capacitance, CK _t and CK _c | 0.2 | 0.8 | 0.2 | 0.7 | pF | 1,3 |
| C _{DCK} | Input capacitance delta CK _t and CK _c | - | 0.05 | - | 0.05 | pF | 1,3,4 |
| C _I | Input capacitance(CTRL, ADD, CMD pins only) | 0.2 | 0.8 | 0.2 | 0.7 | pF | 1,3,6 |
| C _{DI_CTRL} | Input capacitance delta(All CTRL pins only) | -0.1 | 0.1 | -0.1 | 0.1 | pF | 1,3,7,8 |
| C _{DI_ADD_CMD} | Input capacitance delta(All ADD/CMD pins only) | -0.1 | 0.1 | -0.1 | 0.1 | pF | 1,2,9,10 |
| C _{ALERT} | Input/output capacitance of ALERT | 0.5 | 1.5 | 0.5 | 1.5 | pF | 1,3 |
| C _{ZQ} | Input/output capacitance of ZQ | 0.5 | 2.3 | 0.5 | 2.3 | pF | 1,3,12 |
| C _{TEN} | Input capacitance of TEN | 0.2 | 2.3 | 0.2 | 2.3 | pF | 1,3,13 |

NOTE:

1. This parameter is not subject to production test. It is verified by design and characterization. The silicon only capacitance is validated by de-embedding the package L & C parasitic. The capacitance is measured with VDD, VDDQ, VSS, VSSQ applied with all other signal pins floating. Measurement procedure tbd.
2. DQ, DM_n, DQS_T, DQS_c, TDQS_T, TDQS_C. Although the DM, TDQS_T and TDQS_C pins have different functions, the loading matches DQ and DQS
3. This parameter applies to monolithic devices only; stacked/dual-die devices are not covered here
4. Absolute value CK_T-CK_C
5. Absolute value of CIO(DQS_T)-CIO(DQS_c)
6. C_I applies to ODT, CS_n, CKE, A0-A17, BA0-BA1, BG0-BG1, RAS_n/A16, CAS_n/A15, WE_n/A14, ACT_n and PAR.
7. C_{DI_CTRL} applies to ODT, CS_n and CKE
8. $C_{DI_CTRL} = C_I(CTRL) - 0.5 * (C_I(CLK_T) + C_I(CLK_C))$
9. C_{DI_ADD_CMD} applies to, A0-A17, BA0-BA1, BG0-BG1, RAS_n/A16, CAS_n/A15, WE_n/A14, ACT_n and PAR.
10. $C_{DI_ADD_CMD} = C_I(ADD_CMD) - 0.5 * (C_I(CLK_T) + C_I(CLK_C))$
11. $C_{DIO} = C_{IO}(DQ, DM) - 0.5 * (C_{IO}(DQS_T) + C_{IO}(DQS_c))$
12. Maximum external load capacitance on ZQ pin: tbd pF.
13. TEN pin may be DRAM internally pulled low through a weak pull-down resistor to VSS. In this case C_{TEN} might not be valid and system shall verify TEN signal with Vendor specific information.

16. Electrical Characteristics and AC Timing

16.1 Speed Bins and CL, tRCD, tRP, tRC and tRAS for Corresponding Bin

[Table 22] DDR4-1600 Speed Bins and Operations

| Speed Bin | | | DDR4-1600 | | Unit | NOTE | |
|-----------------------------------------------------------|---------|----------|-----------------|-----------------|------|------|-----------|
| CL-nRCD-nRP | | | 11-11-11 | | | | |
| Parameter | Symbol | | min | max | | | |
| Internal read command to first data | tAA | | 13.75 | 18.00 | ns | 10 | |
| Internal read command to first data with read DBI enabled | tAA_DBI | | tAA(min) + 2nCK | tAA(max) + 2nCK | ns | 10 | |
| ACT to internal read or write delay time | tRCD | | 13.75 | - | ns | 10 | |
| PRE command period | tRP | | 13.75 | - | ns | 10 | |
| ACT to PRE command period | tRAS | | 35 | 9 x tREFI | ns | 10 | |
| ACT to ACT or REF command period | tRC | | 48.75 | - | ns | 10 | |
| | Normal | Read DBI | | | | | |
| CWL = 9 | CL = 9 | CL = 11 | tCK(AVG) | Reserved | | ns | 1,2,3,4,9 |
| | CL = 10 | CL = 12 | tCK(AVG) | 1.5 | 1.6 | ns | 1,2,3,4,9 |
| CWL = 9,11 | CL = 10 | CL = 12 | tCK(AVG) | Reserved | | ns | 1,2,3,4 |
| | CL = 11 | CL = 13 | tCK(AVG) | 1.25 | <1.5 | ns | 1,2,3,4 |
| | CL = 12 | CL = 14 | tCK(AVG) | 1.25 | <1.5 | ns | 1,2,3 |
| Supported CL Settings | | | 10,11,12 | | nCK | | |
| Supported CL Settings with read DBI | | | 12,13,14 | | nCK | | |
| Supported CWL Settings | | | 9,11 | | nCK | | |

[Table 23] DDR4-1866 Speed Bins and Operations

| Speed Bin | | | DDR4-1866 | | Unit | NOTE | |
|-----------------------------------------------------------|---------|----------|-----------------|-----------------|-------|------|-----------|
| CL-nRCD-nRP | | | 13-13-13 | | | | |
| Parameter | Symbol | | min | max | | | |
| Internal read command to first data | tAA | | 13.92 | 18.00 | ns | 10 | |
| Internal read command to first data with read DBI enabled | tAA_DBI | | tAA(min) + 2nCK | tAA(max) + 2nCK | ns | 10 | |
| ACT to internal read or write delay time | tRCD | | 13.92 | - | ns | 10 | |
| PRE command period | tRP | | 13.92 | - | ns | 10 | |
| ACT to PRE command period | tRAS | | 34 | 9 x tREFI | ns | 10 | |
| ACT to ACT or REF command period | tRC | | 47.92 | - | ns | 10 | |
| | Normal | Read DBI | | | | | |
| CWL = 9 | CL = 9 | CL = 11 | tCK(AVG) | Reserved | | ns | 1,2,3,4,9 |
| | CL = 10 | CL = 12 | tCK(AVG) | 1.5 | 1.6 | ns | 1,2,3,4,9 |
| CWL = 9,11 | CL = 10 | CL = 12 | tCK(AVG) | Reserved | | ns | 4 |
| | CL = 11 | CL = 13 | tCK(AVG) | 1.25 | <1.5 | ns | 1,2,3,4,6 |
| | CL = 12 | CL = 14 | tCK(AVG) | 1.25 | <1.5 | ns | 1,2,3,6 |
| CWL = 10,12 | CL = 12 | CL = 14 | tCK(AVG) | Reserved | | ns | 1,2,3,4 |
| | CL = 13 | CL = 15 | tCK(AVG) | 1.071 | <1.25 | ns | 1,2,3,4 |
| | CL = 14 | CL = 16 | tCK(AVG) | 1.071 | <1.25 | ns | 1,2,3 |
| Supported CL Settings | | | 10,11,12,13,14 | | nCK | | |
| Supported CL Settings with read DBI | | | 12,13,14,15,16 | | nCK | | |
| Supported CWL Settings | | | 9,10,11,12 | | nCK | | |

[Table 24] DDR4-2133 Speed Bins and Operations

| Speed Bin | | | DDR4-2133 | | Unit | NOTE | |
|-----------------------------------------------------------|---------|-------------------------------|----------------------|----------|--------|------|-----------|
| CL-nRCD-nRP | | | 15-15-15 | | | | |
| Parameter | Symbol | min | max | | | | |
| Internal read command to first data | tAA | 14.06 (13.75) ⁵ | 18.00 | ns | 10 | | |
| Internal read command to first data with read DBI enabled | tAA_DBI | tAA(min) + 3nCK | tAA(max) + 3nCK | ns | 10 | | |
| ACT to internal read or write delay time | tRCD | 14.06 (13.75) ⁵ | - | ns | 10 | | |
| PRE command period | tRP | 14.06 (13.75) ⁵ | - | ns | 10 | | |
| ACT to PRE command period | tRAS | 33 | 9 x tREFI | ns | 10 | | |
| ACT to ACT or REF command period | tRC | 47.06 (46.75) ⁵ | - | ns | 10 | | |
| | Normal | Read DBI | | | | | |
| CWL = 9 | CL = 9 | CL = 11 | tCK(AVG) | Reserved | | ns | 1,2,3,4,9 |
| | CL = 10 | CL = 12 | tCK(AVG) | 1.5 | 1.6 | ns | 1,2,3,4,9 |
| CWL = 9,11 | CL = 11 | CL = 13 | tCK(AVG) | 1.25 | <1.5 | ns | 1,2,3,4,7 |
| | CL = 12 | CL = 14 | tCK(AVG) | 1.25 | <1.5 | ns | 1,2,3,7 |
| CWL = 10,12 | CL = 13 | CL = 15 | tCK(AVG) | 1.071 | <1.25 | ns | 1,2,3,4,7 |
| | CL = 14 | CL = 16 | tCK(AVG) | 1.071 | <1.25 | ns | 1,2,3,7 |
| CWL = 11,14 | CL = 14 | CL = 17 | tCK(AVG) | Reserved | | ns | 1,2,3,4 |
| | CL = 15 | CL = 18 | tCK(AVG) | 0.938 | <1.071 | ns | 1,2,3,4 |
| | CL = 16 | CL = 19 | tCK(AVG) | 0.938 | <1.071 | ns | 1,2,3 |
| Supported CL Settings | | | 10,11,12,13,14,15,16 | | nCK | | |
| Supported CL Settings with read DBI | | | 12,13,14,15,16,18,19 | | nCK | | |
| Supported CWL Settings | | | 9,10,11,12,14 | | nCK | | |

[Table 25] DDR4-2400 Speed Bins and Operations

| Speed Bin | | | DDR4-2400 | | Unit | NOTE | |
|-----------------------------------------------------------|---------|-------------------------------|----------------------------|----------|--------|-----------|-----------|
| CL-nRCD-nRP | | | 17-17-17 | | | | |
| Parameter | Symbol | min | max | | | | |
| Internal read command to first data | tAA | 14.16 (13.75) ⁵ | 18.00 | ns | 10 | | |
| Internal read command to first data with read DBI enabled | tAA_DBI | tAA(min) + 3nCK | tAA(max) + 3nCK | ns | 10 | | |
| ACT to internal read or write delay time | tRCD | 14.16 (13.75) ⁵ | - | ns | 10 | | |
| PRE command period | tRP | 14.16 (13.75) ⁵ | - | ns | 10 | | |
| ACT to PRE command period | tRAS | 32 | 9 x tREFI | ns | 10 | | |
| ACT to ACT or REF command period | tRC | 46.16 (45.75) ⁵ | - | ns | 10 | | |
| | Normal | Read DBI | | | | | |
| CWL = 9 | CL = 9 | CL = 11 | tCK(AVG) | Reserved | ns | 1,2,3,4,9 | |
| | CL = 10 | CL = 12 | tCK(AVG) | 1.5 | 1.6 | ns | 1,2,3,4,9 |
| CWL = 9,11 | CL = 10 | CL = 12 | tCK(AVG) | Reserved | ns | 4 | |
| | CL = 11 | CL = 13 | tCK(AVG) | 1.25 | <1.5 | ns | 1,2,3,4,8 |
| | CL = 12 | CL = 14 | tCK(AVG) | 1.25 | <1.5 | ns | 1,2,3,8 |
| CWL = 10,12 | CL = 12 | CL = 14 | tCK(AVG) | Reserved | ns | 4 | |
| | CL = 13 | CL = 15 | tCK(AVG) | 1.071 | <1.25 | ns | 1,2,3,4,8 |
| | CL = 14 | CL = 16 | tCK(AVG) | 1.071 | <1.25 | ns | 1,2,3,8 |
| CWL = 11,14 | CL = 14 | CL = 17 | tCK(AVG) | Reserved | ns | 4 | |
| | CL = 15 | CL = 18 | tCK(AVG) | 0.938 | <1.071 | ns | 1,2,3,4,8 |
| | CL = 16 | CL = 19 | tCK(AVG) | 0.938 | <1.071 | ns | 1,2,3,8 |
| CWL = 12,16 | CL = 15 | CL = 18 | tCK(AVG) | Reserved | ns | 1,2,3,4 | |
| | CL = 16 | CL = 19 | tCK(AVG) | Reserved | ns | 1,2,3,4 | |
| | CL = 17 | CL = 20 | tCK(AVG) | 0.833 | <0.938 | | |
| | CL = 18 | CL = 21 | tCK(AVG) | 0.833 | <0.938 | ns | 1,2,3 |
| Supported CL Settings | | | 10,11,12,13,14,15,16,17,18 | | nCK | | |
| Supported CL Settings with read DBI | | | 12,13,14,15,16,18,19,20,21 | | nCK | | |
| Supported CWL Settings | | | 9,10,11,12,14,16 | | nCK | | |

16.2 Speed Bin Table Note

Absolute Specification

- VDDQ = VDD = 1.20V +/- 0.06 V
- VPP = 2.5V +0.25/-0.125 V
- The values defined with above-mentioned table are DLL ON case.
- DDR4-1600, 1866, 2133 and 2400 Speed Bin Tables are valid only when Geardown Mode is disabled.

1. The CL setting and CWL setting result in tCK(avg).MIN and tCK(avg).MAX requirements. When making a selection of tCK(avg), both need to be fulfilled: Requirements from CL setting as well as requirements from CWL setting.
2. tCK(avg).MIN limits: Since CAS Latency is not purely analog - data and strobe output are synchronized by the DLL - all possible intermediate frequencies may not be guaranteed. An application should use the next smaller JEDEC standard tCK(avg) value (1.5, 1.25, 1.071, 0.938 or 0.833 ns) when calculating CL [nCK] = tAA [ns] / tCK(avg) [ns], rounding up to the next 'Supported CL', where tAA = 12.5ns and tCK(avg) = 1.3 ns should only be used for CL = 10 calculation.
3. tCK(avg).MAX limits: Calculate tCK(avg) = tAA.MAX / CL SELECTED and round the resulting tCK(avg) down to the next valid speed bin (i.e. 1.5ns or 1.25ns or 1.071 ns or 0.938 ns or 0.833 ns). This result is tCK(avg).MAX corresponding to CL SELECTED.
4. 'Reserved' settings are not allowed. User must program a different value.
5. 'Optional' settings allow certain devices in the industry to support this setting, however, it is not a mandatory feature. Refer to supplier's data sheet and/or the DIMM SPD information if and how this setting is supported.
6. Any DDR4-1866 speed bin also supports functional operation at lower frequencies as shown in the table which are not subject to Production Tests but verified by Design/Characterization.
7. Any DDR4-2133 speed bin also supports functional operation at lower frequencies as shown in the table which are not subject to Production Tests but verified by Design/Characterization.
8. Any DDR4-2400 speed bin also supports functional operation at lower frequencies as shown in the table which are not subject to Production Tests but verified by Design/Characterization.
9. DDR4-1600 AC timing apply if DRAM operates at lower than 1600 MT/s data rate.
10. Parameters apply from tCK(avg)min to tCK(avg)max at all standard JEDEC clock period values as stated in the Speed Bin Tables.

17. Timing Parameters by Speed Grade

[Table 26] Timing Parameters by Speed Bin for DDR4-1600 to DDR4-2400

| Speed | | DDR4-1600 | | DDR4-1866 | | DDR4-2133 | | DDR4-2400 | | Units | NOTE | |
|-------------------------------------------------------------------------------------|----------------|------------------------------------------------------------------------------------------------------------------------|--------------------------------|---------------------------------|--------------------------------|---------------------------------|--------------------------------|---------------------------------|--------------------------------|----------|-------|--|
| Parameter | Symbol | MIN | MAX | MIN | MAX | MIN | MAX | MIN | MAX | | | |
| Clock Timing | | | | | | | | | | | | |
| Minimum Clock Cycle Time (DLL off mode) | tCK (DLL_OFF) | 8 | 20 | 8 | 20 | 8 | 20 | 8 | 20 | ns | | |
| Average Clock Period | tCK(avg) | 1.25 | <1.5 | 1.071 | <1.25 | 0.938 | <1.071 | 0.833 | <0.938 | ns | 35,36 | |
| Average high pulse width | tCH(avg) | 0.48 | 0.52 | 0.48 | 0.52 | 0.48 | 0.52 | 0.48 | 0.52 | tCK(avg) | | |
| Average low pulse width | tCL(avg) | 0.48 | 0.52 | 0.48 | 0.52 | 0.48 | 0.52 | 0.48 | 0.52 | tCK(avg) | | |
| Absolute Clock Period | tCK(abs) | tCK(avg)min + tJIT(per)min_to t | tCK(avg)max + tJIT(per)max_tot | tCK(avg)min + tJIT(per)min_to t | tCK(avg)max + tJIT(per)max_tot | tCK(avg)min + tJIT(per)min_to t | tCK(avg)max + tJIT(per)max_tot | tCK(avg)min + tJIT(per)min_to t | tCK(avg)max + tJIT(per)max_tot | tCK(avg) | | |
| Absolute clock HIGH pulse width | tCH(abs) | 0.45 | - | 0.45 | - | 0.45 | - | 0.45 | - | tCK(avg) | 23 | |
| Absolute clock LOW pulse width | tCL(abs) | 0.45 | - | 0.45 | - | 0.45 | - | 0.45 | - | tCK(avg) | 24 | |
| Clock Period Jitter- total | JIT(per)_tot | -63 | 63 | -54 | 54 | -47 | 47 | -42 | 42 | ps | 23 | |
| Clock Period Jitter- deterministic | JIT(per)_dj | -31 | 31 | -27 | 27 | -23 | 23 | -21 | 21 | ps | 26 | |
| Clock Period Jitter during DLL locking period | tJIT(per, lck) | -50 | 50 | -43 | 43 | -38 | 38 | -33 | 33 | ps | | |
| Cycle to Cycle Period Jitter | tJIT(cc)_total | 125 | | 107 | | 94 | | 83 | | ps | 25 | |
| Cycle to Cycle Period Jitter deterministic | tJIT(cc)_dj | 63 | | 54 | | 47 | | 42 | | ps | 26 | |
| Cycle to Cycle Period Jitter during DLL locking period | tJIT(cc, lck) | 100 | | 86 | | 75 | | 67 | | ps | | |
| Duty Cycle Jitter | tJIT(duty) | TBD | TBD | TBD | TBD | TBD | TBD | TBD | TBD | ps | | |
| Cumulative error across 2 cycles | tERR(2per) | -92 | 92 | -79 | 79 | -69 | 69 | -61 | 61 | ps | | |
| Cumulative error across 3 cycles | tERR(3per) | -109 | 109 | -94 | 94 | -82 | 82 | -73 | 73 | ps | | |
| Cumulative error across 4 cycles | tERR(4per) | -121 | 121 | -104 | 104 | -91 | 91 | -81 | 81 | ps | | |
| Cumulative error across 5 cycles | tERR(5per) | -131 | 131 | -112 | 112 | -98 | 98 | -87 | 87 | ps | | |
| Cumulative error across 6 cycles | tERR(6per) | -139 | 139 | -119 | 119 | -104 | 104 | -92 | 92 | ps | | |
| Cumulative error across 7 cycles | tERR(7per) | -145 | 145 | -124 | 124 | -109 | 109 | -97 | 97 | ps | | |
| Cumulative error across 8 cycles | tERR(8per) | -151 | 151 | -129 | 129 | -113 | 113 | -101 | 101 | ps | | |
| Cumulative error across 9 cycles | tERR(9per) | -156 | 156 | -134 | 134 | -117 | 117 | -104 | 104 | ps | | |
| Cumulative error across 10 cycles | tERR(10per) | -160 | 160 | -137 | 137 | -120 | 120 | -107 | 107 | ps | | |
| Cumulative error across 11 cycles | tERR(11per) | -164 | 164 | -141 | 141 | -123 | 123 | -110 | 110 | ps | | |
| Cumulative error across 12 cycles | tERR(12per) | -168 | 168 | -144 | 144 | -126 | 126 | -112 | 112 | ps | | |
| Cumulative error across 13 cycles | tERR(13per) | -172 | 172 | -147 | 147 | -129 | 129 | -114 | 114 | ps | | |
| Cumulative error across 14 cycles | tERR(14per) | -175 | 175 | -150 | 150 | -131 | 131 | -116 | 116 | ps | | |
| Cumulative error across 15 cycles | tERR(15per) | -178 | 178 | -152 | 152 | -133 | 133 | -118 | 118 | ps | | |
| Cumulative error across 16 cycles | tERR(16per) | -180 | 189 | -155 | 155 | -135 | 135 | -120 | 120 | ps | | |
| Cumulative error across 17 cycles | tERR(17per) | -183 | 183 | -157 | 157 | -137 | 137 | -122 | 122 | ps | | |
| Cumulative error across 18 cycles | tERR(18per) | -185 | 185 | -159 | 159 | -139 | 139 | -124 | 124 | ps | | |
| Cumulative error across n = 13, 14, ... 49, 50 cycles | tERR(nper) | $tERR(nper)min = ((1 + 0.68ln(n)) * tJIT(per)_total min)$ $tERR(nper)max = ((1 + 0.68ln(n)) * tJIT(per)_total max)$ | | | | | | | | | ps | |
| Command and Address setup time to CK_t, CK_c referenced to Vih(ac) / Vil(ac) levels | tIS(base) | 115 | - | 100 | - | 80 | - | 62 | - | ps | | |
| Command and Address setup time to CK_t, CK_c referenced to Vref levels | tIS(Vref) | 215 | - | 200 | - | 180 | - | 162 | - | ps | | |
| Command and Address hold time to CK_t, CK_c referenced to Vih(dc) / Vil(dc) levels | tIH(base) | 140 | - | 125 | - | 105 | - | 87 | - | ps | | |
| Command and Address hold time to CK_t, CK_c referenced to Vref levels | tIH(Vref) | 215 | - | 200 | - | 180 | - | 162 | - | ps | | |
| Control and Address Input pulse width for each input | tIPW | 600 | - | 525 | - | 460 | - | 410 | - | ps | | |
| Command and Address Timing | | | | | | | | | | | | |

| Speed | | DDR4-1600 | | DDR4-1866 | | DDR4-2133 | | DDR4-2400 | | Units | NOTE | |
|-------------------------------------------------------------------------------------------------------------------------------|----------------|--------------------------------------------|------|--------------------------|------|--------------------------|------|--------------------------|------|-------------|----------|--|
| Parameter | Symbol | MIN | MAX | MIN | MAX | MIN | MAX | MIN | MAX | | | |
| CAS_n to CAS_n command delay for same bank group | tCCD_L | max(5 nCK, 6.250 ns) | - | max(5 nCK, 5.355 ns) | - | max(5 nCK, 5.355 ns) | - | max(5 nCK, 5 ns) | - | nCK | 34 | |
| CAS_n to CAS_n command delay for different bank group | tCCD_S | 4 | - | 4 | - | 4 | - | 4 | - | nCK | 34 | |
| ACTIVATE to ACTIVATE Command delay to different bank group for 2KB page size | tRRD_S(2K) | Max(4nCK, 6ns) | - | Max(4nCK, 5.3ns) | - | Max(4nCK, 5.3ns) | - | Max(4nCK, 5.3ns) | - | nCK | 34 | |
| ACTIVATE to ACTIVATE Command delay to different bank group for 2KB page size | tRRD_S(1K) | Max(4nCK, 5ns) | - | Max(4nCK, 4.2ns) | - | Max(4nCK, 3.7ns) | - | Max(4nCK, 3.3ns) | - | nCK | 34 | |
| ACTIVATE to ACTIVATE Command delay to different bank group for 1/2KB page size | tRRD_S(1/2K) | Max(4nCK, 5ns) | - | Max(4nCK, 4.2ns) | - | Max(4nCK, 3.7ns) | - | Max(4nCK, 3.3ns) | - | nCK | 34 | |
| ACTIVATE to ACTIVATE Command delay to same bank group for 2KB page size | tRRD_L(2K) | Max(4nCK, 7.5ns) | - | Max(4nCK, 6.4ns) | - | Max(4nCK, 6.4ns) | - | Max(4nCK, 6.4ns) | - | nCK | 34 | |
| ACTIVATE to ACTIVATE Command delay to same bank group for 1KB page size | tRRD_L(1K) | Max(4nCK, 6ns) | - | Max(4nCK, 5.3ns) | - | Max(4nCK, 5.3ns) | - | Max(4nCK, 4.9ns) | - | nCK | 34 | |
| ACTIVATE to ACTIVATE Command delay to same bank group for 1/2KB page size | tRRD_L(1/2K) | Max(4nCK, 6ns) | - | Max(4nCK, 5.3ns) | - | Max(4nCK, 5.3ns) | - | Max(4nCK, 4.9ns) | - | nCK | 34 | |
| Four activate window for 2KB page size | tFAW_2K | Max(28nCK, 35ns) | - | Max(28nCK, 30ns) | - | Max(28nCK, 30ns) | - | Max(28nCK, 30ns) | - | ns | 34 | |
| Four activate window for 1KB page size | tFAW_1K | Max(20nCK, 25ns) | - | Max(20nCK, 23ns) | - | Max(20nCK, 21ns) | - | Max(20nCK, 21ns) | - | ns | 34 | |
| Four activate window for 1/2KB page size | tFAW_1/2K | Max(16nCK, 20ns) | - | Max(16nCK, 17ns) | - | Max(16nCK, 17ns) | - | Max(16nCK, 13ns) | - | ns | 34 | |
| Delay from start of internal write transaction to internal read command for different bank group | tWTR_S | max(2nCK, 2.5ns) | - | max(2nCK, 2.5ns) | - | max(2nCK, 2.5ns) | - | max(2nCK, 2.5ns) | - | | 1,2,e,34 | |
| Delay from start of internal write transaction to internal read command for same bank group | tWTR_L | max(4nCK, 7.5ns) | - | max(4nCK, 7.5ns) | - | max(4nCK, 7.5ns) | - | max(4nCK, 7.5ns) | - | | 1,34 | |
| Internal READ Command to PRE-CHARGE Command delay | tRTP | max(4nCK, 7.5ns) | - | max(4nCK, 7.5ns) | - | max(4nCK, 7.5ns) | - | max(4nCK, 7.5ns) | - | | | |
| WRITE recovery time | tWR | 15 | - | 15 | - | 15 | - | 15 | - | ns | 1 | |
| Write recovery time when CRC and DM are enabled | tWR_CRC_DM | tWR+max(4nCK, 3.75ns) | - | tWR+max(5nCK, 3.75ns) | - | tWR+max(5nCK, 3.75ns) | - | tWR+max(5nCK, 3.75ns) | - | ns | 1, 28 | |
| delay from start of internal write transaction to internal read command for different bank group with both CRC and DM enabled | tWTR_S_C RC_DM | tWTR_S+max(4nCK, 3.75ns) | - | tWTR_S+max(5nCK, 3.75ns) | - | tWTR_S+max(5nCK, 3.75ns) | - | tWTR_S+max(5nCK, 3.75ns) | - | ns | 2, 29,34 | |
| delay from start of internal write transaction to internal read command for same bank group with both CRC and DM enabled | tWTR_L_C RC_DM | tWTR_L+max(4nCK, 3.75ns) | - | tWTR_L+max(5nCK, 3.75ns) | - | tWTR_L+max(5nCK, 3.75ns) | - | tWTR_L+max(5nCK, 3.75ns) | - | ns | 3,30,34 | |
| DLL locking time | tDLLK | 597 | - | 597 | - | 768 | - | 768 | - | nCK | | |
| Mode Register Set command cycle time | tMRD | 8 | - | 8 | - | 8 | - | 8 | - | nCK | | |
| Mode Register Set command update delay | tMOD | max(24nCK, 15ns) | - | max(24nCK, 15ns) | - | max(24nCK, 15ns) | - | max(24nCK, 15ns) | - | | | |
| Multi-Purpose Register Recovery Time | tMPRR | 1 | - | 1 | - | 1 | - | 1 | - | nCK | 33 | |
| Multi Purpose Register Write Recovery Time | tWR_MPR | tMOD (min) + AL + PL | - | tMOD (min) + AL + PL | - | tMOD (min) + AL + PL | - | tMOD (min) + AL + PL | - | - | | |
| Auto precharge write recovery + precharge time | tDAL(min) | Programmed WR + roundup (tRP / tCK(avg)) | | | | | | | | | nCK | |
| DQ0 or DQL0 driven to 0 set-up time to first DQS rising edge | tPDA_S | 0.5 | - | 0.5 | - | 0.5 | - | 0.5 | - | UI | 45,47 | |
| DQ0 or DQL0 driven to 0 hold time from last DQS fall-ing edge | tPDA_H | 0.5 | - | 0.5 | - | 0.5 | - | 0.5 | - | UI | 46,47 | |
| CS_n to Command Address Latency | | | | | | | | | | | | |
| CS_n to Command Address Latency | tCAL | 3 | - | 4 | - | 4 | - | 5 | - | nCK | | |
| DRAM Data Timing | | | | | | | | | | | | |
| DQS_t,DQS_c to DQ skew, per group, per access | tDQSQ | - | 0.16 | - | 0.16 | - | 0.16 | - | 0.16 | tCK(avg) /2 | 13,18 | |
| DQ output hold time from DQS_t,DQS_c | tQH | 0.76 | - | 0.76 | - | 0.76 | - | 0.76 | - | tCK(avg) /2 | 13,17,18 | |
| Data Valid Window per device: tQH - tDQSQ for a device | tDVWd | 0.63 | - | 0.63 | - | 0.64 | - | 0.64 | - | UI | 16,17,18 | |

| Speed | | DDR4-1600 | | DDR4-1866 | | DDR4-2133 | | DDR4-2400 | | Units | NOTE |
|-----------------------------------------------------------------------------------------|-----------------|----------------------------|--------|----------------------------|--------|----------------------------|--------|----------------------------|--------|-------|----------|
| Parameter | Symbol | MIN | MAX | MIN | MAX | MIN | MAX | MIN | MAX | | |
| Data Valid Window per device, per pin: tQH - tDQSQ each device's output | tDVWp | 0.66 | - | 0.66 | - | 0.69 | - | 0.72 | - | UI | 16,17,18 |
| Data Strobe Timing | | | | | | | | | | | |
| DQS_t, DQS_c differential READ Preamble | tRPRE | 0.9 | NOTE44 | 0.9 | NOTE44 | 0.9 | NOTE44 | 0.9 | NOTE44 | tCK | 40 |
| | | NA | NA | NA | NA | NA | NA | 1.8 | NOTE44 | tCK | 41 |
| DQS_t, DQS_c differential READ Postamble | tRPST | 0.33 | TBD | 0.33 | TBD | 0.33 | TBD | 0.33 | TBD | tCK | |
| DQS_t, DQS_c differential output high time | tQSH | 0.4 | - | 0.4 | - | 0.4 | - | 0.4 | - | tCK | 21 |
| DQS_t, DQS_c differential output low time | tQSL | 0.4 | - | 0.4 | - | 0.4 | - | 0.4 | - | tCK | 20 |
| DQS_t, DQS_c differential WRITE Preamble | tWPRE | 0.9 | - | 0.9 | - | 0.9 | - | 0.9 | - | tCK | 42 |
| | | NA | NA | NA | NA | NA | NA | 1.8 | NA | tCK | 43 |
| DQS_t, DQS_c differential WRITE Postamble | tWPST | 0.33 | TBD | 0.33 | TBD | 0.33 | TBD | 0.33 | TBD | tCK | |
| DQS_t and DQS_c low-impedance time (Referenced from RL-1) | tLZ(DQS) | -450 | 225 | -390 | 195 | -360 | 180 | -300 | 150 | ps | |
| DQS_t and DQS_c high-impedance time (Referenced from RL+BL/2) | tHZ(DQS) | - | 225 | - | 195 | - | 180 | - | 150 | ps | |
| DQS_t, DQS_c differential input low pulse width | tDQSL | 0.46 | 0.54 | 0.46 | 0.54 | 0.46 | 0.54 | 0.46 | 0.54 | tCK | |
| DQS_t, DQS_c differential input high pulse width | tDQSH | 0.46 | 0.54 | 0.46 | 0.54 | 0.46 | 0.54 | 0.46 | 0.54 | tCK | |
| DQS_t, DQS_c rising edge to CK_t, CK_c rising edge (1 clock preamble) | tDQSS | -0.27 | 0.27 | -0.27 | 0.27 | -0.27 | 0.27 | -0.27 | 0.27 | tCK | |
| DQS_t, DQS_c falling edge setup time to CK_t, CK_c rising edge | tDSS | 0.18 | - | 0.18 | - | 0.18 | - | 0.18 | - | tCK | |
| DQS_t, DQS_c falling edge hold time from CK_t, CK_c rising edge | tDSH | 0.18 | - | 0.18 | - | 0.18 | - | 0.18 | - | tCK | |
| DQS_t, DQS_c rising edge output timing locatino from rising CK_t, CK_c with DLL On mode | tDQSK (DLL On) | -225 | 225 | -195 | 195 | -180 | 180 | -175 | 175 | ps | 37,38,39 |
| DQS_t, DQS_c rising edge output variance window per DRAM | tDQSK1 (DLL On) | | 370 | | 330 | | 310 | | 290 | ps | 37,38,39 |
| MPSM Timing | | | | | | | | | | | |
| Command path disable delay upon MPSM entry | tMPED | tMOD(min) + tCPDED(min) | - | tMOD(min) + tCPDED(min) | - | tMOD(min) + tCPDED(min) | - | tMOD(min) + tCPDED(min) | - | | |
| Valid clock requirement after MPSM entry | tCKMPE | tMOD(min) + tCPDED(min) | - | tMOD(min) + tCPDED(min) | - | tMOD(min) + tCPDED(min) | - | tMOD(min) + tCPDED(min) | - | | |
| Valid clock requirement before MPSM exit | tCKMPX | tCKSRX(min) | | tCKSRX(min) | | tCKSRX(min) | | tCKSRX(min) | | | |
| Exit MPSM to commands not requiring a locked DLL | tXMP | txs(imin) | | txs(imin) | | txs(imin) | | txs(imin) | | | |
| Exit MPSM to commands requiring a locked DLL | tXMPDLL | tXMP(min) + tXSDLL(min) | | tXMP(min) + tXSDLL(min) | | tXMP(min) + tXSDLL(min) | | tXMP(min) + tXSDLL(min) | | | |
| CS setup time to CKE | tMPX_S | tISmin + tIH-min | - | tISmin + tIH-min | - | tISmin + tIH-min | - | tISmin + tIH-min | - | | |
| Calibration Timing | | | | | | | | | | | |
| Power-up and RESET calibration time | tZQinit | 1024 | - | 1024 | - | 1024 | - | 1024 | - | nCK | |
| Normal operation Full calibration time | tZQoper | 512 | - | 512 | - | 512 | - | 512 | - | nCK | |
| Normal operation Short calibration time | tZQCS | 128 | - | 128 | - | 128 | - | 128 | - | nCK | |
| Reset/Self Refresh Timing | | | | | | | | | | | |
| Exit Reset from CKE HIGH to a valid command | tXPR | max (5nCK, tRFC(min)+10ns) | - | max (5nCK, tRFC(min)+10ns) | - | max (5nCK, tRFC(min)+10ns) | - | max (5nCK, tRFC(min)+10ns) | - | | |
| Exit Self Refresh to commands not requiring a locked DLL | tXS | tRFC(min)+10ns | - | tRFC(min)+10ns | - | tRFC(min)+10ns | - | tRFC(min)+10ns | - | | |
| SRX to commands not requiring a locked DLL in Self Refresh ABORT | tX_S_ABORT(min) | tRFC4(min)+10ns | - | tRFC4(min)+10ns | - | tRFC4(min)+10ns | - | tRFC4(min)+10ns | - | | |

| Speed | | DDR4-1600 | | DDR4-1866 | | DDR4-2133 | | DDR4-2400 | | Units | NOTE |
|-----------------------------------------------------------------------------------------------------------------------------------|----------------|---------------------|---------|---------------------|---------|---------------------|---------|---------------------|---------|----------|-------|
| Parameter | Symbol | MIN | MAX | MIN | MAX | MIN | MAX | MIN | MAX | | |
| Exit Self Refresh to ZQCL,ZQCS and MRS (CL,CWL,WR,RTP and Gear Down) | tXS_FAST (min) | tRFC4(min)+10ns | - | tRFC4(min)+10ns | - | tRFC4(min)+10ns | - | tRFC4(min)+10ns | - | | |
| Exit Self Refresh to commands requiring a locked DLL | tXSDLL | tDLLK(min) | - | tDLLK(min) | - | tDLLK(min) | - | tDLLK(min) | - | | |
| Minimum CKE low width for Self refresh entry to exit timing | tCKESR | tCKE(min)+1nCK | - | tCKE(min)+1nCK | - | tCKE(min)+1nCK | - | tCKE(min)+1nCK | - | | |
| Minimum CKE low width for Self refresh entry to exit timing with CA Parity enabled | tCKESR_PAR | tCKE(min)+1nCK+PL | - | tCKE(min)+1nCK+PL | - | tCKE(min)+1nCK+PL | - | tCKE(min)+1nCK+PL | - | | |
| Valid Clock Requirement after Self Refresh Entry (SRE) or Power-Down Entry (PDE) | tCKSRE | max(5nCK,10ns) | - | max(5nCK,10ns) | - | max(5nCK,10ns) | - | max(5nCK,10ns) | - | | |
| Valid Clock Requirement after Self Refresh Entry (SRE) or Power-Down when CA Parity is enabled | tCKS-RE_PAR | max(5nCK,10ns)+PL | - | max(5nCK,10ns)+PL | - | max(5nCK,10ns)+PL | - | max(5nCK,10ns)+PL | - | | |
| Valid Clock Requirement before Self Refresh Exit (SRX) or Power-Down Exit (PDX) or Reset Exit | tCKSRX | max(5nCK,10ns) | - | max(5nCK,10ns) | - | max(5nCK,10ns) | - | max(5nCK,10ns) | - | | |
| Power Down Timing | | | | | | | | | | | |
| Exit Power Down with DLL on to any valid command;Exit Precharge Power Down with DLL frozen to commands not requiring a locked DLL | tXP | max(4nCK,6ns) | - | max(4nCK,6ns) | - | max(4nCK,6ns) | - | max(4nCK,6ns) | - | | |
| CKE minimum pulse width | tCKE | max(3nCK,5ns) | - | max(3nCK,5ns) | - | max(3nCK,5ns) | - | max(3nCK,5ns) | - | | 31,32 |
| Command pass disable delay | tCPDED | 4 | - | 4 | - | 4 | - | 4 | - | nCK | |
| Power Down Entry to Exit Timing | tPD | tCKE(min) | 9*tREFI | tCKE(min) | 9*tREFI | tCKE(min) | 9*tREFI | tCKE(min) | 9*tREFI | | 6 |
| Timing of ACT command to Power Down entry | tACTPDEN | 1 | - | 1 | - | 2 | - | 2 | - | nCK | 7 |
| Timing of PRE or PREA command to Power Down entry | tPRPDEN | 1 | - | 1 | - | 2 | - | 2 | - | nCK | 7 |
| Timing of RD/RDA command to Power Down entry | tRDPDEN | RL+4+1 | - | RL+4+1 | - | RL+4+1 | - | RL+4+1 | - | nCK | |
| Timing of WR command to Power Down entry (BL8OTF, BL8MRS, BC4OTF) | tWRPDEN | WL+4+(tWR/tCK(avg)) | - | WL+4+(tWR/tCK(avg)) | - | WL+4+(tWR/tCK(avg)) | - | WL+4+(tWR/tCK(avg)) | - | nCK | 4 |
| Timing of WRA command to Power Down entry (BL8OTF, BL8MRS, BC4OTF) | tWRAPDEN | WL+4+WR+1 | - | WL+4+WR+1 | - | WL+4+WR+1 | - | WL+4+WR+1 | - | nCK | 5 |
| Timing of WR command to Power Down entry (BC4MRS) | tWRP-BC4DEN | WL+2+(tWR/tCK(avg)) | - | WL+2+(tWR/tCK(avg)) | - | WL+2+(tWR/tCK(avg)) | - | WL+2+(tWR/tCK(avg)) | - | nCK | 4 |
| Timing of WRA command to Power Down entry (BC4MRS) | tWRAP-BC4DEN | WL+2+WR+1 | - | WL+2+WR+1 | - | WL+2+WR+1 | - | WL+2+WR+1 | - | nCK | 5 |
| Timing of REF command to Power Down entry | tREFPDEN | 1 | - | 1 | - | 2 | - | 2 | - | nCK | 7 |
| Timing of MRS command to Power Down entry | tMRSPDEN | tMOD(min) | - | tMOD(min) | - | tMOD(min) | - | tMOD(min) | - | | |
| PDA Timing | | | | | | | | | | | |
| Mode Register Set command cycle time in PDA mode | tMRD_PDA | max(16nCK,10ns) | | max(16nCK,10ns) | | max(16nCK,10ns) | | max(16nCK,10ns) | | | |
| Mode Register Set command update delay in PDA mode | tMOD_PDA | tMOD | | tMOD | | tMOD | | tMOD | | | |
| ODT Timing | | | | | | | | | | | |
| Asynchronous RTT turn-on delay (Power-Down with DLL frozen) | tAONAS | 1.0 | 9.0 | 1.0 | 9.0 | 1.0 | 9.0 | 1.0 | 9.0 | ns | |
| Asynchronous RTT turn-off delay (Power-Down with DLL frozen) | tAOFAS | 1.0 | 9.0 | 1.0 | 9.0 | 1.0 | 9.0 | 1.0 | 9.0 | ns | |
| RTT dynamic change skew | tADC | 0.3 | 0.7 | 0.3 | 0.7 | 0.3 | 0.7 | 0.3 | 0.7 | tCK(avg) | |
| Write Leveling Timing | | | | | | | | | | | |
| First DQS_t/DQS_n rising edge after write leveling mode is programmed | tWLMRD | 40 | - | 40 | - | 40 | - | 40 | - | nCK | 12 |
| DQS_t/DQS_n delay after write leveling mode is programmed | tWLDQSEN | 25 | - | 25 | - | 25 | - | 25 | - | nCK | 12 |
| Write leveling setup time from rising CK_t, CK_c crossing to rising DQS_t/DQS_n crossing | tWLS | 0.13 | - | 0.13 | - | 0.13 | - | 0.13 | - | tCK(avg) | |
| Write leveling hold time from rising DQS_t/DQS_n crossing to rising CK_t, CK_c crossing | tWLH | 0.13 | - | 0.13 | - | 0.13 | - | 0.13 | - | tCK(avg) | |

datasheet

Registered DIMM

DDR4 SDRAM

| Speed | | DDR4-1600 | | DDR4-1866 | | DDR4-2133 | | DDR4-2400 | | Units | NOTE |
|-----------------------------------------------------------------------------------------------------------------|----------------|-----------|--------|-----------|--------|-----------|--------|-----------|--------|-------|------|
| Parameter | Symbol | MIN | MAX | MIN | MAX | MIN | MAX | MIN | MAX | | |
| Write leveling output delay | tWLO | 0 | 9.5 | 0 | 9.5 | 0 | 9.5 | 0 | 9.5 | ns | |
| Write leveling output error | tWLOE | | | | | | | | | ns | |
| CA Parity Timing | | | | | | | | | | | |
| Commands not guaranteed to be executed during this time | tPAR_UNKNOWN | - | PL | - | PL | - | PL | - | PL | | |
| Delay from errant command to ALERT_n assertion | tPAR_ALERT_ON | - | PL+6ns | - | PL+6ns | - | PL+6ns | - | PL+6ns | | |
| Pulse width of ALERT_n signal when asserted | tPAR_ALERT_PW | 48 | 96 | 56 | 112 | 64 | 128 | 72 | 144 | nCK | |
| Time from when Alert is asserted till controller must start providing DES commands in Persistent CA parity mode | tPAR_ALERT_RSP | - | 43 | - | 50 | - | 57 | - | 64 | nCK | |
| Parity Latency | PL | 4 | | 4 | | 4 | | 5 | | nCK | |
| CRC Error Reporting | | | | | | | | | | | |
| CRC error to ALERT_n latency | tCRC_ALERT_T | 3 | 13 | 3 | 13 | 3 | 13 | 3 | 13 | ns | |
| CRC ALERT_n pulse width | CRC_ALERT_T_PW | 6 | 10 | 6 | 10 | 6 | 10 | 6 | 10 | nCK | |
| tREFI | | | | | | | | | | | |
| tRFC1 (min) | 2Gb | 160 | - | 160 | - | 160 | - | 160 | - | ns | 34 |
| | 4Gb | 260 | - | 260 | - | 260 | - | 260 | - | ns | 34 |
| | 8Gb | 350 | - | 350 | - | 350 | - | 350 | - | ns | 34 |
| | 16Gb | TBD | - | TBD | - | TBD | - | TBD | - | ns | 34 |
| tRFC2 (min) | 2Gb | 110 | - | 110 | - | 110 | - | 110 | - | ns | 34 |
| | 4Gb | 160 | - | 160 | - | 160 | - | 160 | - | ns | 34 |
| | 8Gb | 260 | - | 260 | - | 260 | - | 260 | - | ns | 34 |
| | 16Gb | TBD | - | TBD | - | TBD | - | TBD | - | ns | 34 |
| tRFC4 (min) | 2Gb | 90 | - | 90 | - | 90 | - | 90 | - | ns | 34 |
| | 4Gb | 110 | - | 110 | - | 110 | - | 110 | - | ns | 34 |
| | 8Gb | 160 | - | 160 | - | 160 | - | 160 | - | ns | 34 |
| | 16Gb | TBD | - | TBD | - | TBD | - | TBD | - | ns | 34 |

NOTE :

1. Start of internal write transaction is defined as follows :
For BL8 (Fixed by MRS and on-the-fly) : Rising clock edge 4 clock cycles after WL.
For BC4 (on-the-fly) : Rising clock edge 4 clock cycles after WL.
For BC4 (fixed by MRS) : Rising clock edge 2 clock cycles after WL.
2. A separate timing parameter will cover the delay from write to read when CRC and DM are simultaneously enabled
3. Commands requiring a locked DLL are: READ (and RAP) and synchronous ODT commands.
4. tWR is defined in ns, for calculation of tWRPDEN it is necessary to round up tWR/tCK to the next integer.
5. WR in clock cycles as programmed in MR0.
6. tREFI depends on TOPER.
7. CE is allowed to be registered low while operations such as row activation, precharge, autoprecharge or refresh are in progress, but power-down IDD spec will not be applied until finishing those operations.
8. For these parameters, the DDR4 SDRAM device supports $t_{nPARAM}[nCK]=RU\{t_{PARAM}[ns]/t_{CK}(avg)[ns]\}$, which is in clock cycles assuming all input clock jitter specifications are satisfied
9. When CRC and DM are both enabled, tWR_CRC_DM is used in place of tWR.
10. When CRC and DM are both enabled tWTR_S_CRC_DM is used in place of tWTR_S.
11. When CRC and DM are both enabled tWTR_L_CRC_DM is used in place of tWTR_L.
12. The max values are system dependent.
13. DQ to DQS total timing per group where the total includes the sum of deterministic and random timing terms for a specified BER. BER spec and measurement method are tbd.
14. The deterministic component of the total timing. Measurement method tbd.
15. DQ to DQ static offset relative to strobe per group. Measurement method tbd.
16. This parameter will be characterized and guaranteed by design.
17. When the device is operated with the input clock jitter, this parameter needs to be derated by the actual $t_{jit(per)}_{total}$ of the input clock. (output deratings are relative to the SDRAM input clock). Example tbd.
18. DRAM DBI mode is off.
19. DRAM DBI mode is enabled. Applicable to x8 and x16 DRAM only.
20. tQSL describes the instantaneous differential output low pulse width on DQS_t - DQS_c, as measured from on falling edge to the next consecutive rising edge
21. tQSH describes the instantaneous differential output high pulse width on DQS_t - DQS_c, as measured from on falling edge to the next consecutive rising edge
22. There is no maximum cycle time limit besides the need to satisfy the refresh interval tREFI
23. tCH(abs) is the absolute instantaneous clock high pulse width, as measured from one rising edge to the following falling edge
24. tCL(abs) is the absolute instantaneous clock low pulse width, as measured from one falling edge to the following rising edge
25. Total jitter includes the sum of deterministic and random jitter terms for a specified BER. BER target and measurement method are tbd.
26. The deterministic jitter component out of the total jitter. This parameter is characterized and guaranteed by design.
27. This parameter has to be even number of clocks
28. When CRC and DM are both enabled, tWR_CRC_DM is used in place of tWR.
29. When CRC and DM are both enabled tWTR_S_CRC_DM is used in place of tWTR_S.
30. When CRC and DM are both enabled tWTR_L_CRC_DM is used in place of tWTR_L.
31. After CE is registered LOW, CE signal level shall be maintained below VILDC for tCKE specification (Low pulse width).
32. After CE is registered HIGH, CE signal level shall be maintained above VIHDC for tCKE specification (HIGH pulse width).
33. Defined between end of MPR read burst and MRS which reloads MPR or disables MPR function.
34. Parameters apply from tCK(avg)min to tCK(avg)max at all standard JEDEC clock period values as stated in the Speed Bin Tables.
35. This parameter must keep consistency with Speed-Bin Tables shown in Device Operation.
36. DDR4-1600 AC timing apply if DRAM operates at lower than 1600 MT/s data rate.
 $UI=t_{CK}(avg).min/2$
37. applied when DRAM is in DLL ON mode.
38. Assume no jitter on input clock signals to the DRAM
39. Value is only valid for RZQ/7
40. 1tCK toggle mode with setting MR4:A11 to 0
41. 2tCK toggle mode with setting MR4:A11 to 1, which is valid for DDR4-2400 speed grade.
42. 1tCK mode with setting MR4:A12 to 0
43. 2tCK mode with setting MR4:A12 to 1, which is valid for DDR4-2400 speed grade.
44. The maximum read preamble is bounded by tLZ(DQS)min on the left side and tDQSCK(max) on the right side. See Device Operation. to Data Strobe Relationship". Boundary of DQS Low-Z occur one cycle earlier in 2tCK toggle mode which is illustrated in See Device Operation Preamble".
45. DQ falling signal middle-point of transferring from High to Low to first rising edge of DQS diff-signal cross-point
46. last falling edge of DQS diff-signal cross-point to DQ rising signal middle-point of transferring from Low to High
47. VrefDQ value must be set to either its midpoint or Vcent_DQ(midpoint) in order to capture DQ0 or DQL0 low level for entering PDA mode.

18. Physical Dimensions

18.1 2Gx4 based 2Gx72 Module (1 Rank) - M393A2K40BB0/M393A2K40BB1

Units : Millimeters

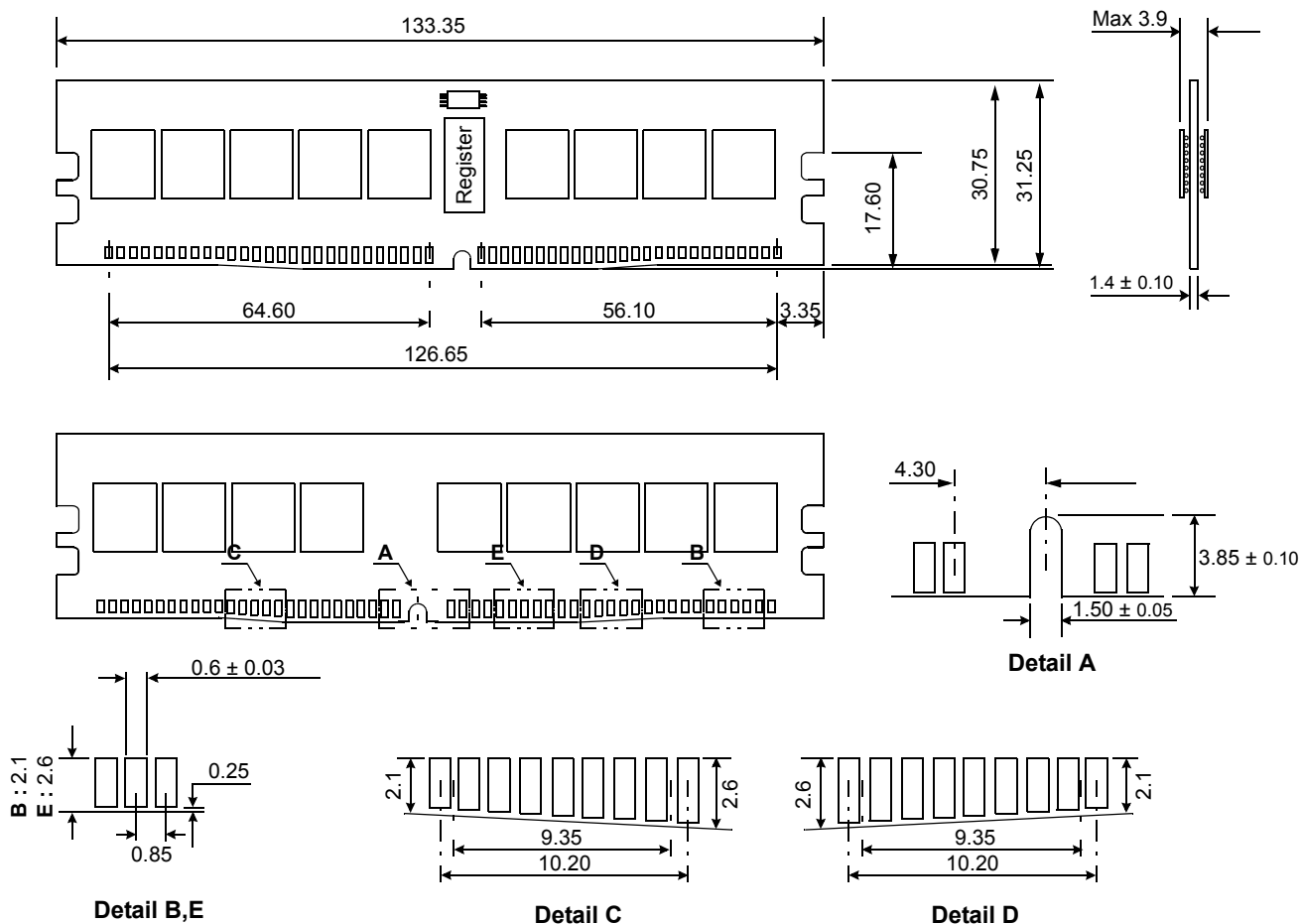

18.1.1 2Gx72 DIMM, populated as one physical rank of x4 DDR4 SDRAMs

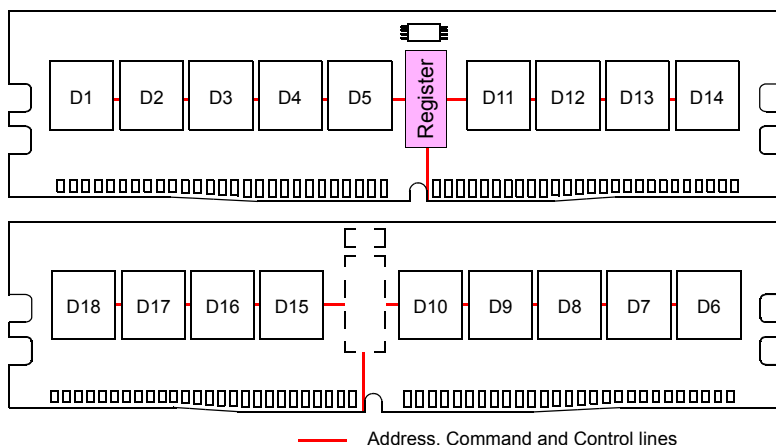

The used device is 2G x4 DDR4 SDRAM, Flip-Chip.
 DDR4 SDRAM Part NO : K4A8G045WB-BC**

* NOTE : Tolerances on all dimensions ± 0.15 unless otherwise specified.

18.2 2Gx4 based 4Gx72 Module (2 Ranks) - M393A4K40BB0/M393A4K40BB1

Units : Millimeters

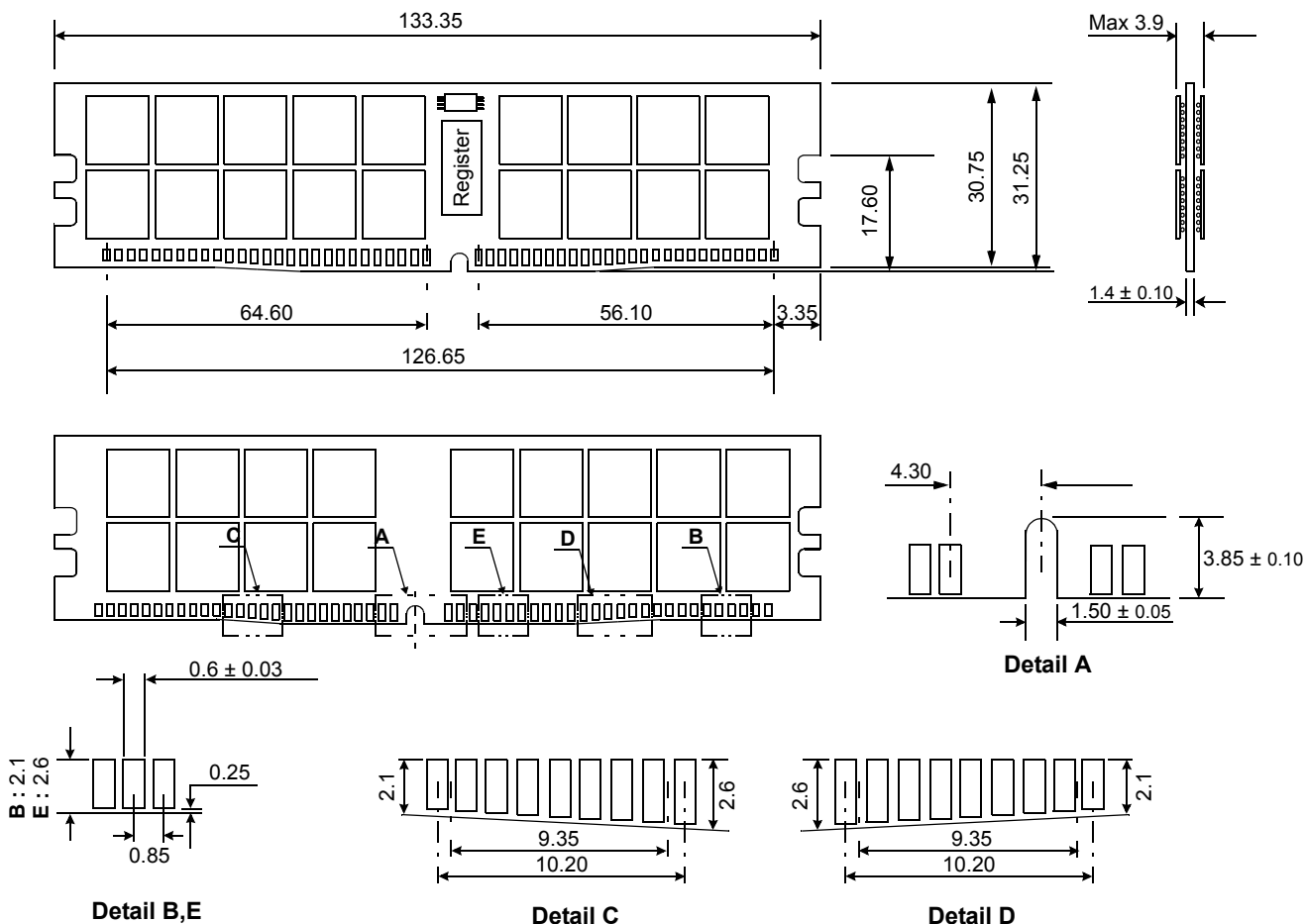

18.2.1 4Gx72 DIMM, populated as two physical ranks of x4 DDR4 SDRAMs

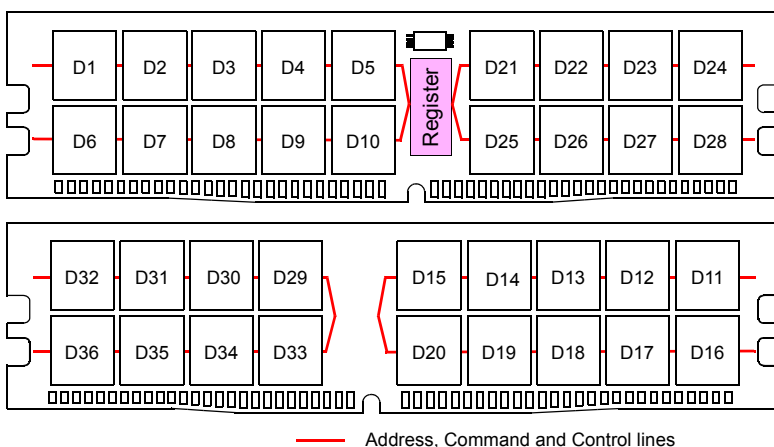

The used device is 2G x4 DDR4 SDRAM, Flip-Chip.
 DDR4 SDRAM Part NO : K4A8G045WB-BC**

* NOTE : Tolerances on all dimensions ±0.15 unless otherwise specified.