

# ASROCK

## FM2A88M EXTREME4+

User Manual



Version 1.0

Published August 2013

Copyright©2013 ASRock INC. All rights reserved.

## Copyright Notice:

No part of this documentation may be reproduced, transcribed, transmitted, or translated in any language, in any form or by any means, except duplication of documentation by the purchaser for backup purpose, without written consent of ASRock Inc.

Products and corporate names appearing in this documentation may or may not be registered trademarks or copyrights of their respective companies, and are used only for identification or explanation and to the owners' benefit, without intent to infringe.

## Disclaimer:

Specifications and information contained in this documentation are furnished for informational use only and subject to change without notice, and should not be constructed as a commitment by ASRock. ASRock assumes no responsibility for any errors or omissions that may appear in this documentation.

With respect to the contents of this documentation, ASRock does not provide warranty of any kind, either expressed or implied, including but not limited to the implied warranties or conditions of merchantability or fitness for a particular purpose.

In no event shall ASRock, its directors, officers, employees, or agents be liable for any indirect, special, incidental, or consequential damages (including damages for loss of profits, loss of business, loss of data, interruption of business and the like), even if ASRock has been advised of the possibility of such damages arising from any defect or error in the documentation or product.

The terms HDMI™ and HDMI High-Definition Multimedia Interface, and the HDMI logo are trademarks or registered trademarks of HDMI Licensing LLC in the United States and other countries.



This device complies with Part 15 of the FCC Rules. Operation is subject to the following two conditions:

- (1) this device may not cause harmful interference, and
- (2) this device must accept any interference received, including interference that may cause undesired operation.

## CALIFORNIA, USA ONLY

The Lithium battery adopted on this motherboard contains Perchlorate, a toxic substance controlled in Perchlorate Best Management Practices (BMP) regulations passed by the California Legislature. When you discard the Lithium battery in California, USA, please follow the related regulations in advance.

“Perchlorate Material-special handling may apply, see [www.dtsc.ca.gov/hazardouswaste/perchlorate](http://www.dtsc.ca.gov/hazardouswaste/perchlorate)”

**ASRock Website: <http://www.asrock.com>**

# Contents

<b>1. Introduction .....</b>	<b>1</b>
1.1 Package Contents .....	1
1.2 Specifications.....	2
1.3 Unique Features .....	6
1.4 Motherboard Layout .....	11
1.5 I/O Panel .....	13
<b>2. Installation .....</b>	<b>15</b>
Pre-installation Precautions.....	15
2.1 CPU Installation.....	16
2.2 Installation of CPU Fan and Heatsink .....	17
2.3 Installation of Memory Modules (DIMM).....	18
2.4 Expansion Slots (PCI and PCI Express Slots).....	20
2.5 Jumpers Setup.....	21
2.6 Onboard Headers and Connectors .....	22
2.7 CrossFireX™ and Quad CrossFireX™ Operation Guide.....	27
2.8 Dual Graphics Operation Guide .....	30
<b>3. Software and Utilities Operation.....</b>	<b>32</b>
3.1 Installing Drivers .....	32
3.2 A-Tuning .....	33
3.3 Qualcomm® Atheros® Security Wake On Internet Technology ..	37
3.4 Start8 .....	44
<b>4. UEFI SETUP UTILITY.....</b>	<b>47</b>
4.1 Introduction .....	47
4.1.1 UEFI Menu Bar.....	47
4.1.2 Navigation Keys.....	48
4.2 Main Screen.....	48
4.3 OC Tweaker Screen.....	49
4.4 Advanced Screen .....	52
4.4.1 CPU Configuration.....	53
4.4.2 North Bridge Configuration .....	54
4.4.3 South Bridge Configuration .....	55
4.4.4 Storage Configuration.....	56
4.4.5 Super IO Configuration.....	57
4.4.6 ACPI Configuration .....	58
4.4.7 USB Configuration.....	60
4.4.8 Trusted Computing .....	61

4.5	Tool .....	62
4.6	Hardware Health Event Monitoring Screen .....	65
4.7	Boot Screen .....	66
4.8	Security Screen .....	68
4.9	Exit Screen .....	69

---

# 1. Introduction

Thank you for purchasing ASRock **FM2A88M Extreme4+** motherboard, a reliable motherboard produced under ASRock's consistently stringent quality control. It delivers excellent performance with robust design conforming to ASRock's commitment to quality and endurance.

In this documentation, Chapter 1 and 2 contains the introduction of the motherboard and step-by-step installation guides. Chapter 3 contains the operation guide of the software and utilities. Chapter 4 contains the configuration guide of the BIOS setup.



Because the motherboard specifications and the BIOS software might be updated, the content of this manual will be subject to change without notice. In case any modifications of this manual occur, the updated version will be available on ASRock website without further notice. You may find the latest VGA cards and CPU support lists on ASRock website as well. ASRock website <http://www.asrock.com>

If you require technical support related to this motherboard, please visit our website for specific information about the model you are using.  
[www.asrock.com/support/index.asp](http://www.asrock.com/support/index.asp)

## 1.1 Package Contents

ASRock **FM2A88M Extreme4+** Motherboard (Micro ATX Form Factor)

ASRock **FM2A88M Extreme4+** Quick Installation Guide

ASRock **FM2A88M Extreme4+** Support CD

2 x Serial ATA (SATA) Data Cables (Optional)

1 x I/O Panel Shield



### **ASRock Reminds You...**

To get better performance in Windows® 8 / 8 64-bit / 7 / 7 64-bit, it is recommended to set the BIOS option in Storage Configuration to AHCI mode.

---

## 1.2 Specifications

<b>Platform</b>	<ul style="list-style-type: none"><li>- Micro ATX Form Factor</li><li>- All Solid Capacitor design</li></ul>
<b>A-Style</b>	<ul style="list-style-type: none"><li>- Home Cloud</li></ul>
<b>CPU</b>	<ul style="list-style-type: none"><li>- Supports Socket FM2+ 95W / FM2 100W processors</li><li>- 4 + 2 Power Phase design</li></ul>
<b>Chipset</b>	<ul style="list-style-type: none"><li>- AMD A88X (Bolton-D4)</li></ul>
<b>Memory</b>	<ul style="list-style-type: none"><li>- Dual Channel DDR3 Memory Technology</li><li>- 4 x DDR3 DIMM Slots</li><li>- Supports DDR3 2600+(OC)/2400(OC)/2133(OC)/1866/1600/1333/1066 non-ECC, un-buffered memory (see <b>CAUTION 1</b>)</li><li>* DDR3 2600+ is only supported with two DIMMs.</li><li>- Max. capacity of system memory: 64GB (see <b>CAUTION 2</b>)</li><li>- Supports Intel® Extreme Memory Profile (XMP) 1.3 / 1.2</li><li>- Supports AMD Memory Profile (AMP)</li></ul>
<b>Expansion Slot</b>	<ul style="list-style-type: none"><li>- 1 x PCI Express 3.0 x16 Slot (PCIE1 @ x16 mode)</li><li>* PCIE 3.0 is only supported with FM2+ CPU. With FM2 CPU, it only supports PCIE 2.0.</li><li>- 1 x PCI Express 2.0 x16 Slot (PCIE3 @ x4 mode)</li><li>- 1 x PCI Express 2.0 x1 Slot</li><li>- 1 x PCI Slot</li><li>- Supports AMD Quad CrossFireX™, CrossFireX™ and Dual Graphics</li></ul>
<b>Graphics</b>	<ul style="list-style-type: none"><li>- Integrated AMD Radeon HD 8000/7000 series graphics in A-series APU</li><li>- DirectX 11.1, Pixel Shader 5.6 with FM2+ CPU. DirectX 11, Pixel Shader 5.0 with FM2 CPU.</li><li>- Max. shared memory 2GB</li><li>- Three VGA output options: D-Sub, DVI-D and HDMI Ports</li><li>- Supports Triple Monitor</li><li>- Supports HDMI Technology with max. resolution up to 1920x1200 @ 60Hz</li><li>- Supports Dual-link DVI-D with max. resolution up to 2560x1600 @ 60Hz</li><li>- Supports D-Sub with max. resolution up to 1920x1200 @ 60Hz</li><li>- Supports Auto Lip Sync, Deep Color (12bpc), xvYCC and HBR (High Bit Rate Audio) with HDMI Port (Compliant HDMI monitor is required) (see <b>CAUTION 3</b>)</li><li>- Supports Blu-ray Stereoscopic 3D with HDMI Port</li></ul>

	<ul style="list-style-type: none"> <li>- Supports AMD Steady Video™ 2.0: New video post processing capability for automatic jitter reduction on home/online video</li> <li>- Supports HDCP with DVI-D and HDMI Ports</li> <li>- Supports Full HD 1080p Blu-ray (BD) playback with DVI-D and HDMI Ports</li> </ul>
<b>Audio</b>	<ul style="list-style-type: none"> <li>- 7.1 CH HD Audio with Content Protection (Realtek ALC892 Audio Codec)</li> <li>- Premium Blu-ray Audio support</li> </ul>
<b>LAN</b>	<ul style="list-style-type: none"> <li>- PCIE x1 Gigabit LAN 10/100/1000 Mb/s</li> <li>- Qualcomm® Atheros® AR8171</li> <li>- Supports Qualcomm® Atheros® Security Wake On Internet Technology</li> <li>- Supports Wake-On-LAN</li> <li>- Supports Energy Efficient Ethernet 802.3az</li> <li>- Supports PXE</li> </ul>
<b>Rear Panel I/O</b>	<ul style="list-style-type: none"> <li>- 1 x PS/2 Mouse/Keyboard Port</li> <li>- 1 x D-Sub Port</li> <li>- 1 x DVI-D Port</li> <li>- 1 x HDMI Port</li> <li>- 1 x Optical SPDIF Out Port</li> <li>- 4 x USB 2.0 Ports</li> <li>- 2 x USB 3.0 Ports (AMD A88X (Bolton-D4))</li> <li>- 1 x RJ-45 LAN Port with LED (ACT/LINK LED and SPEED LED)</li> <li>- HD Audio Jacks: Rear Speaker/Central/Bass/Line in/Front Speaker/Microphone</li> </ul>
<b>Storage</b>	<ul style="list-style-type: none"> <li>- 8 x SATA3 6.0 Gb/s Connectors, support RAID (RAID 0, RAID 1, RAID 5 and RAID 10), NCQ, AHCI and Hot Plug</li> </ul>
<b>Connector</b>	<ul style="list-style-type: none"> <li>- 1 x IR Header</li> <li>- 1 x Print Port Header</li> <li>- 1 x COM Port Header</li> <li>- 1 x Chassis Intrusion Header</li> <li>- 1 x TPM Header</li> <li>- 1 x Power LED Header</li> <li>- 2 x CPU Fan Connectors (1 x 4-pin, 1 x 3-pin)</li> <li>- 1 x Chassis Fan Connector (4-pin)</li> <li>- 1 x Power Fan Connector (3-pin)</li> <li>- 1 x 24 pin ATX Power Connector</li> <li>- 1 x 8 pin 12V Power Connector</li> <li>- 1 x Front Panel Audio Connector</li> </ul>

	<ul style="list-style-type: none"> <li>- 3 x USB 2.0 Headers (Support 6 USB 2.0 ports)</li> <li>- 1 x USB 3.0 Header by AMD A88X (Bolton-D4) (Supports 2 USB 3.0 ports)</li> </ul>
<b>BIOS Feature</b>	<ul style="list-style-type: none"> <li>- 64Mb AMI UEFI Legal BIOS with GUI support</li> <li>- Supports "Plug and Play"</li> <li>- ACPI 1.1 compliance wake up events</li> <li>- Supports jumperfree</li> <li>- SMBIOS 2.3.1 support</li> <li>- DRAM, CPU Voltage multi-adjustment</li> </ul>
<b>Support CD</b>	<ul style="list-style-type: none"> <li>- Drivers, Utilities, AntiVirus Software (Trial Version), CyberLink MediaEspresso 6.5 Trial, Google Chrome Browser and Toolbar, Start8 (30 days trial)</li> </ul>
<b>Hardware Monitor</b>	<ul style="list-style-type: none"> <li>- CPU temperature sensing</li> <li>- Chassis temperature sensing</li> <li>- CPU Fan Tachometer</li> <li>- Chassis Fan Tachometer</li> <li>- CPU/Chassis Quiet Fan</li> <li>- CPU/Chassis Fan multi-speed control</li> <li>- CASE OPEN detection</li> <li>- Voltage monitoring: +12V, +5V, +3.3V, Vcore</li> </ul>
<b>OS</b>	<ul style="list-style-type: none"> <li>- Microsoft® Windows® 8.1 32-bit / 8.1 64-bit / 8 32-bit / 8 64-bit / 7 32-bit / 7 64-bit / XP 32-bit</li> </ul>
<b>Certifications</b>	<ul style="list-style-type: none"> <li>- FCC, CE, WHQL</li> <li>- ErP/EuP ready (ErP/EuP ready power supply is required)</li> </ul>

\* For detailed product information, please visit our website: <http://www.asrock.com>

#### **WARNING**

Please realize that there is a certain risk involved with overclocking, including adjusting the setting in the BIOS, applying Untied Overclocking Technology, or using third-party overclocking tools. Overclocking may affect your system's stability, or even cause damage to the components and devices of your system. It should be done at your own risk and expense. We are not responsible for possible damage caused by overclocking.

---

## **CAUTION!**

1. Whether 2600/2400/2133/1866/1600MHz memory speed is supported depends on the CPU you adopt. If you want to adopt DDR3 2600/2400/2133/1866/1600 memory module on this motherboard, please refer to the memory support list on our website for the compatible memory modules.  
ASRock website <http://www.asrock.com>
2. Due to the operating system limitation, the actual memory size may be less than 4GB for the reservation for system usage under Windows® 8 / 7. For Windows® 64-bit OS with 64-bit CPU, there is no such limitation. You can use ASRock XFast RAM to utilize the memory that Windows® cannot use.
3. xvYCC and Deep Color are only supported under Windows® 8 64-bit / 8 / 7 64-bit / 7. Deep Color mode will be enabled only if the display supports 12bpc in EDID. HBR is supported under Windows® 8 64-bit / 8 / 7 64-bit / 7.

---

## 1.3 Unique Features

### **ASRock A-Tuning**

A-Tuning is ASRock's multi purpose software suite with a new interface, more new features and improved utilities, including XFast RAM, Dehumidifier, Good Night LED, FAN-Tastic Tuning, OC Tweaker and a whole lot more.

### **ASRock Instant Boot**

ASRock Instant Boot allows you to turn on your PC in just a few seconds, provides a much more efficient way to save energy, time, money, and improves system running speed for your system. It leverages the S3 and S4 ACPI features which normally enable the Sleep/Standby and Hibernation modes in Windows® to shorten boot up time. By calling S3 and S4 at specific timing during the shutdown and startup process, Instant Boot allows you to enter your Windows® desktop in a few seconds.

### **ASRock Instant Flash**

ASRock Instant Flash is a BIOS flash utility embedded in Flash ROM. This convenient BIOS update tool allows you to update system BIOS without entering operating systems first like MS-DOS or Windows®. With this utility, you can press the <F6> key during the POST or the <F2> key to enter into the BIOS setup menu to access ASRock Instant Flash. Just launch this tool and save the new BIOS file to your USB flash drive, floppy disk or hard drive, then you can update your BIOS only in a few clicks without preparing an additional floppy diskette or other complicated flash utility. Please be noted that the USB flash drive or hard drive must use FAT32/16/12 file system.

### **ASRock APP Charger**

If you desire a faster, less restricted way of charging your Apple devices, such as iPhone/iPad/iPod Touch, ASRock has prepared a wonderful solution for you - ASRock APP Charger. Simply install the APP Charger driver, it makes your iPhone charge much quickly from your computer and up to 40% faster than before. ASRock APP Charger allows you to quickly charge many Apple devices simultaneously and even supports continuous charging when your PC enters into Standby mode (S1),

---

Suspend to RAM (S3), hibernation mode (S4) or power off (S5). With APP Charger driver installed, you can easily enjoy the marvelous charging experience.

### **ASRock XFast USB**

ASRock XFast USB can boost USB storage device performance. The performance may depend on the properties of the device.

### **ASRock XFast LAN**

ASRock XFast LAN provides a faster internet access, which includes the benefits listed below. LAN Application Prioritization: You can configure your application's priority ideally and/or add new programs. Lower Latency in Game: After setting online game's priority higher, it can lower the latency in games. Traffic Shaping: You can watch Youtube HD videos and download simultaneously. Real-Time Analysis of Your Data: With the status window, you can easily recognize which data streams you are transferring currently.

### **ASRock XFast RAM**

ASRock XFast RAM is included in A-Tuning. It fully utilizes the memory space that cannot be used under Windows® 32-bit operating systems. ASRock XFast RAM shortens the loading time of previously visited websites, making web surfing faster than ever. And it also boosts the speed of Adobe Photoshop 5 times faster. Another advantage of ASRock XFast RAM is that it reduces the frequency of accessing your SSDs or HDDs in order to extend their lifespan.

### **ASRock Crashless BIOS**

ASRock Crashless BIOS allows users to update their BIOS without fear of failing. If power loss occurs during the BIOS update process, ASRock Crashless BIOS will automatically finish the BIOS update procedure after regaining power. Please note that BIOS files need to be placed in the root directory of your USB disk. Only USB2.0 ports support this feature.

### **ASRock OMG (Online Management Guard)**

Administrators are able to establish an internet curfew or restrict internet access at specified times via OMG. You may schedule

---

the starting and ending hours of internet access granted to other users. In order to prevent users from bypassing OMG, guest accounts without permission to modify the system time are required.

#### **ASRock Internet Flash**

ASRock Internet Flash searches for available UEFI firmware updates from our servers. In other words, the system can auto-detect the latest UEFI from our servers and flash them without entering Windows® OS.

#### **ASRock UEFI System Browser**

ASRock UEFI system browser is a useful tool included in graphical UEFI. It can detect the devices and configurations that users are currently using in their PC. With the UEFI system browser, you can easily examine the current system configuration in UEFI setup.

#### **ASRock UEFI Tech Service**

Contact ASRock Tech Service by sending a support request from the UEFI setup utility if you are having trouble with your PC.

#### **ASRock On/Off Play Technology**

ASRock On/Off Play Technology allows users to enjoy the great audio experience from the portable audio devices, such like MP3 player or mobile phone to your PC, even when the PC is turned off (or in ACPI S5 mode)! This motherboard also provides a free 3.5mm audio cable (optional) that ensures users the most convenient computing environment.

#### **ASRock Dehumidifier Function**

Users may prevent motherboard damages due to dampness by enabling "Dehumidifier Function". When enabling Dehumidifier Function, the computer will power on automatically to dehumidify the system after entering S4/S5 state.

---

### **ASRock Easy RAID Installer**

ASRock Easy RAID Installer can help you to copy the RAID driver from a support CD to your USB storage device. After copying the RAID driver to your USB storage device, please change "SATA Mode" to "RAID", then you can start installing the OS in RAID mode.

### **ASRock Easy Driver Installer**

For users that don't have an optical disk drive to install the drivers from our support CD, Easy Driver Installer is a handy tool in the UEFI that installs the LAN driver to your system via an USB storage device, then downloads and installs the other required drivers automatically.

### **ASRock Interactive UEFI**

ASRock Interactive UEFI is a blend of system configuration tools, cool sound effects and stunning visuals. The unprecedented UEFI provides a more attractive interface and brings a lot more amusing.

### **ASRock Fast Boot**

With ASRock's exclusive Fast Boot technology, it takes less than 1.5 seconds to logon to Windows® 8 from a cold boot. No more waiting! The speedy boot will completely change your user experience and behavior.

### **ASRock X-Boost**

Brilliantly designed for combo overclocking, ASRock X-Boost Technology is able to unleash the hidden power of your CPUs. Simply press "X" when turning on the PC, X-Boost will automatically overclock the relative components to get up to 15.77% performance boost! With the smart X-Boost, overclocking CPU can become a near one-button process.

### **ASRock Restart to UEFI**

Windows® 8 brings the ultimate boot up experience. The lightning boot up speed makes it hard to access the UEFI setup. ASRock Restart to UEFI technology is designed for those requiring frequent UEFI access. It is included in ASRock's exclusive all-in-one A-Tuning tuning program that allows users to easily enter the UEFI automatically when turning on the PC next time. Just

---

simply enable this function; the PC will be assured to access the UEFI directly in the very beginning.

### **ASRock USB Key**

In a world where time is money, why waste precious time everyday typing usernames to log in to Windows? Why should we even bother memorizing those foot long passwords? Just plug in the USB Key and let your computer log in to windows automatically!

### **ASRock FAN-Tastic Tuning**

ASRock FAN-Tastic Tuning is included in A-Tuning. Configure up to five different fan speeds using the graph. The fans will automatically shift to the next speed level when the assigned temperature is met.

# 1.4 Motherboard Layout

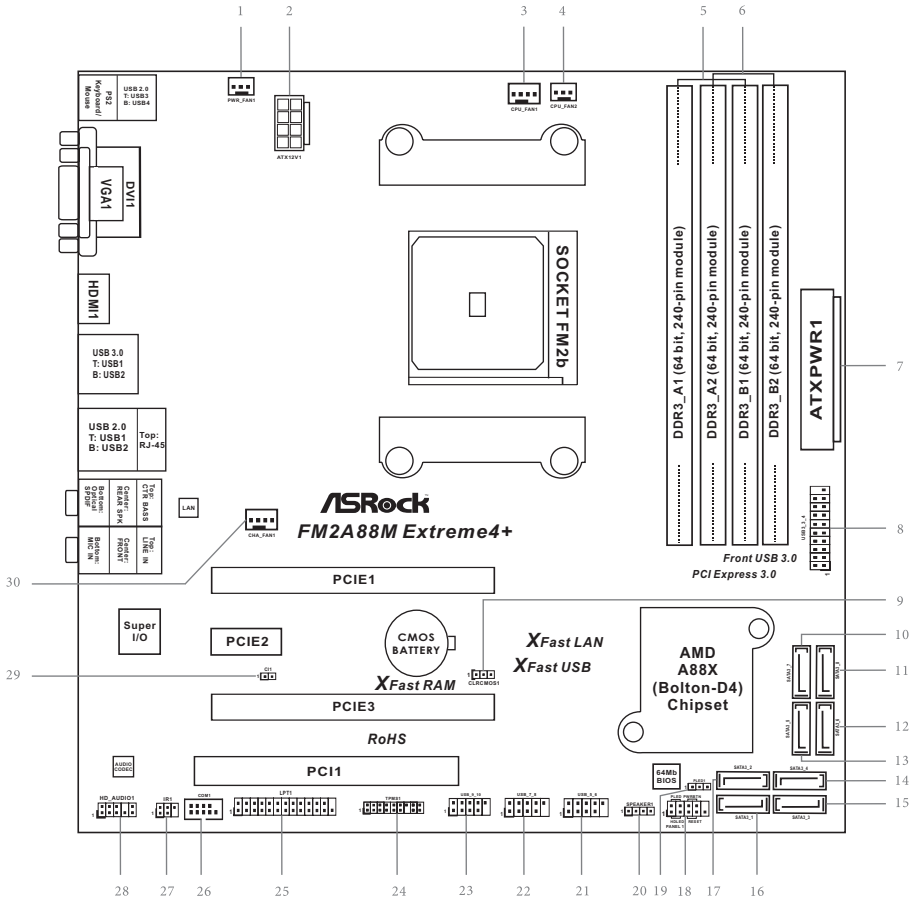

---

No.	Description
-----	-------------

- |    |  |
|----|--|
| 1  | Power Fan Connector (PWR_FAN1)                 |
| 2  | ATX 12V Power Connector (ATX12V1)              |
| 3  | CPU Fan Connector (CPU_FAN1)                   |
| 4  | CPU Fan Connector (CPU_FAN2)                   |
| 5  | 2 x 240-pin DDR3 DIMM Slots (DDR3_A1, DDR3_B1) |
| 6  | 2 x 240-pin DDR3 DIMM Slots (DDR3_A2, DDR3_B2) |
| 7  | ATX Power Connector (ATXPWR1)                  |
| 8  | USB 3.0 Header (USB3_3_4)                      |
| 9  | Clear CMOS Jumper (CLRCMOS1)                   |
| 10 | SATA3 Connector (SATA3_7)                      |
| 11 | SATA3 Connector (SATA3_8)                      |
| 12 | SATA3 Connector (SATA3_6)                      |
| 13 | SATA3 Connector (SATA3_5)                      |
| 14 | SATA3 Connector (SATA3_4)                      |
| 15 | SATA3 Connector (SATA3_3)                      |
| 16 | SATA3 Connector (SATA3_1)                      |
| 17 | SATA3 Connector (SATA3_2)                      |
| 18 | System Panel Header (PANEL1)                   |
| 19 | Power LED Header (PLED1)                       |
| 20 | Chassis Speaker Header (SPEAKER1)              |
| 21 | USB 2.0 Header (USB_5_6)                       |
| 22 | USB 2.0 Header (USB_7_8)                       |
| 23 | USB 2.0 Header (USB_9_10)                      |
| 24 | TPM Header (TPMS1)                             |
| 25 | Print Port Header (LPT1)                       |
| 26 | COM Port Header (COM1)                         |
| 27 | Infrared Module Header (IR1)                   |
| 28 | Front Panel Audio Header (HD_AUDIO1)           |
| 29 | Chassis Intrusion Header (CI1)                 |
| 30 | Chassis Fan Connector (CHA_FAN1)               |

## 1.5 I/O Panel

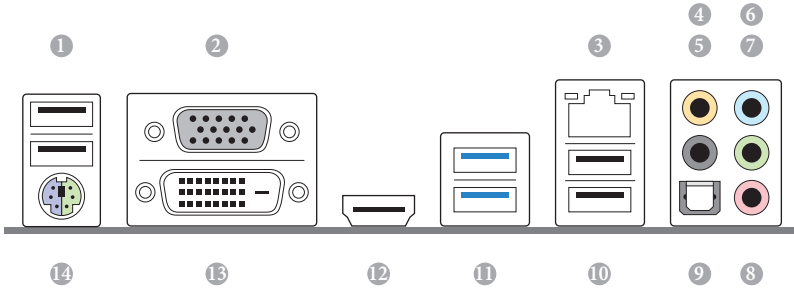

No.	Description	No.	Description
1	USB 2.0 Ports (USB_3_4)*	8	Microphone (Pink)
2	D-Sub Port	9	Optical SPDIF Out Port
3	LAN RJ-45 Port**	10	USB 2.0 Ports (USB_1_2)*
4	Central / Bass (Orange)	11	USB 3.0 Ports (USB3_1_2) (AMD A88X (Bolton-D4))
5	Rear Speaker (Black)	12	HDMI Port
6	Line In (Light Blue)	13	DVI-D Port
7	Front Speaker (Lime)***	14	PS/2 Mouse/Keyboard Port

\* It is recommended to install the USB Keyboard/Mouse cable to USB 2.0 ports (USB\_1\_2 or USB\_3\_4) instead of USB 3.0 ports.

\*\* There are two LEDs on the LAN port. Please refer to the table below for the LAN port LED indications.

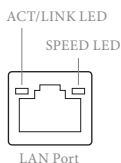

Activity / Link LED		Speed LED	
Status	Description	Status	Description
Off	No Link	Off	10Mbps connection
Blinking	Data Activity	Orange	100Mbps connection
On	Link	Green	1Gbps connection

\*\*\* If you use a 2-channel speaker, please connect the speaker's plug into "Front Speaker Jack". See the table below for connection details in accordance with the type of speaker you use.

Audio Output Channels	Front Speaker (No. 7)	Rear Speaker (No. 5)	Central / Bass (No. 4)	Line In or Side Speaker (No. 6)
2	V	--	--	--
4	V	V	--	--
6	V	V	V	--
8	V	V	V	V

To enable Multi-Streaming, you need to connect a front panel audio cable to the front panel audio header. After restarting your computer, you will find the "Mixer" tool on your system. Please select "Mixer ToolBox" , click "Enable playback multi-streaming", and click "ok". Choose "2CH", "4CH", "6CH", or "8CH" and then you are allowed to select "Realtek HDA Primary output" to use the Rear Speaker, Central/Bass, and Front Speaker, or select "Realtek HDA Audio 2nd output" to use the front panel audio.

---

## 2. Installation

This is a Micro ATX form factor motherboard. Before you install the motherboard, study the configuration of your chassis to ensure that the motherboard fits into it.

### Pre-installation Precautions

Take note of the following precautions before you install motherboard components or change any motherboard settings.



Before you install or remove any component, ensure that the power is switched off or the power cord is detached from the power supply. Failure to do so may cause severe damage to the motherboard, peripherals, and/or components.

1. Unplug the power cord from the wall socket before touching any component.
2. To avoid damaging the motherboard components due to static electricity, NEVER place your motherboard directly on the carpet or the like. Also remember to use a grounded wrist strap or touch a safety grounded object before you handle components.
3. Hold components by the edges and do not touch the ICs.
4. Whenever you uninstall any component, place it on a grounded anti-static pad or in the bag that comes with the component.
5. When placing screws into the screw holes to secure the motherboard to the chassis, please do not over-tighten the screws! Doing so may damage the motherboard.

---

## 2.1 CPU Installation

Step 1. Unlock the socket by lifting the lever up to a 90° angle.

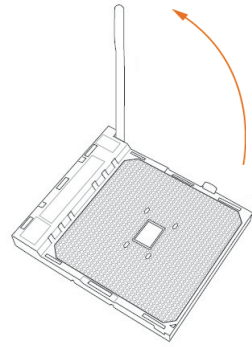

Step 2. Position the CPU directly above the socket such that the CPU corner with the golden triangle matches the socket corner with a small triangle.

Step 3. Carefully insert the CPU into the socket until it fits in place.



The CPU fits only in one correct orientation. DO NOT force the CPU into the socket to avoid bending of the pins.

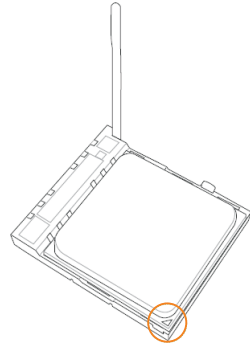

Step 4. When the CPU is in place, press it firmly on the socket while you push down the socket lever to secure the CPU. The lever clicks on the side tab to indicate that it is locked.

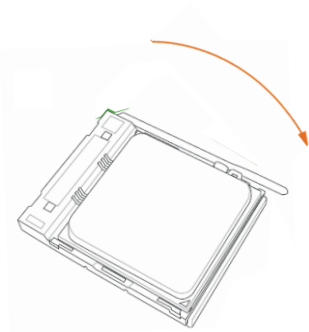

---

## 2.2 Installation of CPU Fan and Heatsink

After you install the CPU into this motherboard, it is necessary to install a larger heatsink and cooling fan to dissipate heat. You also need to spray thermal grease between the CPU and the heatsink to improve heat dissipation. Make sure that the CPU and the heatsink are securely fastened and in good contact with each other. Then connect the CPU fan to the CPU FAN connector (CPU\_FAN1, see Page 11, No. 3 or CPU\_FAN2, see Page 11, No. 4). For proper installation, please kindly refer to the instruction manuals of the CPU fan and the heatsink.

---

## 2.3 Installation of Memory Modules (DIMM)

This motherboard provides four 240-pin DDR3 (Double Data Rate 3) DIMM slots, and supports Dual Channel Memory Technology.



1. For dual channel configuration, you always need to install identical (the same brand, speed, size and chip-type) DDR3 DIMM pairs.
2. It is unable to activate Dual Channel Memory Technology with only one or three memory module installed.
3. It is not allowed to install a DDR or DDR2 memory module into a DDR3 slot; otherwise, this motherboard and DIMM may be damaged.
4. If you adopt DDR3 2600/2400/2133/1866/1600 memory modules on this motherboard, it is recommended to install them on DDR3\_A2 and DDR3\_B2 slots.

### Dual Channel Memory Configuration

Priority	DDR3_A1	DDR3_A2	DDR3_B1	DDR3_B2
1	Populated		Populated	
2		Populated		Populated
3	Populated	Populated	Populated	Populated



The DIMM only fits in one correct orientation. It will cause permanent damage to the motherboard and the DIMM if you force the DIMM into the slot at incorrect orientation.

---

1

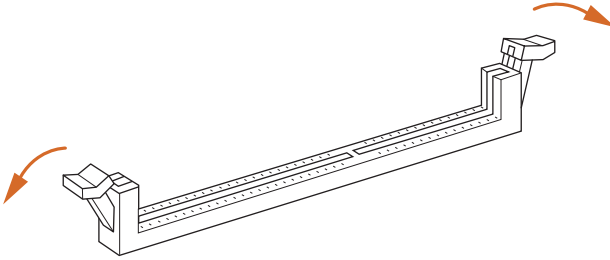

2

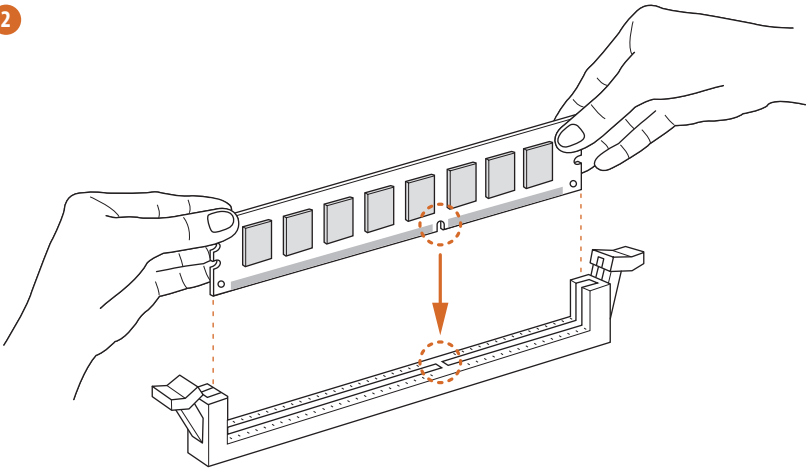

3

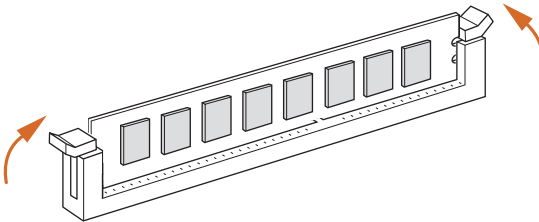

---

## 2.4 Expansion Slots (PCI and PCI Express Slots)

There is 1 PCI slot and 3 PCI Express slots on this motherboard.



*Before installing an expansion card, please make sure that the power supply is switched off or the power cord is unplugged. Please read the documentation of the expansion card and make necessary hardware settings for the card before you start the installation.*

**PCI Slots:** PCI slots are used to install expansion cards that have the 32-bit PCI interface.

**PCIe Slots:**

PCIe1 (PCIe 3.0 x16 slot) is used for PCI Express x16 lane width graphics cards.

PCIe2 (PCIe 2.0 x1 slot) is used for PCI Express cards with x1 lane width cards.

PCIe3 (PCIe 2.0 x16 slot) is used for PCI Express x4 lane width graphics cards.

### PCIe Slot Configurations

	PCIe1	PCIe3
<b>Single Graphics Card</b>	x16	N/A
<b>Two Graphics Cards in CrossFireX™ Mode</b>	x16	x4





*For a better thermal environment, please connect a chassis fan to the motherboard's chassis fan connector (CHA\_FAN1) when using multiple graphics cards.*

---

## 2.5 Jumpers Setup

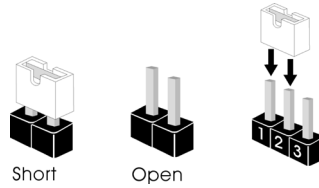
The illustration shows how jumpers are setup. When the jumper cap is placed on pins, the jumper is “Short”. If no jumper cap is placed on pins, the jumper is “Open”. The illustration shows a 3-pin jumper whose pin1 and pin2 are “Short” when jumper cap is placed on these 2 pins.



Jumper	Setting	Description
Clear CMOS Jumper (CLRCMOS1) (see p.11, No. 9)	<b>1_2</b>  Default	<b>2_3</b>  Clear CMOS

Note: CLRCMOS1 allows you to clear the data in CMOS. To clear and reset the system parameters to default setup, please turn off the computer and unplug the power cord from the power supply. After waiting for 15 seconds, use a jumper cap to short pin2 and pin3 on CLRCMOS1 for 5 seconds. However, please do not clear the CMOS right after you update the BIOS. If you need to clear the CMOS when you just finish updating the BIOS, you must boot up the system first, and then shut it down before you do the clear-CMOS action. Please be noted that the password, date, time, user default profile, 1394 GUID and MAC address will be cleared only if the CMOS battery is removed.



If you clear the CMOS, the case open may be detected. Please adjust the BIOS option “Clear Status” to clear the record of previous chassis intrusion status.

## 2.6 Onboard Headers and Connectors



Onboard headers and connectors are NOT jumpers. Do NOT place jumper caps over these headers and connectors. Placing jumper caps over the headers and connectors will cause permanent damage of the motherboard!

### Serial ATA3 Connectors

- (SATA3\_1: see p.11, No. 16)
- (SATA3\_2: see p.11, No. 17)
- (SATA3\_3: see p.11, No. 15)
- (SATA3\_4: see p.11, No. 14)
- (SATA3\_5: see p.11, No. 13)
- (SATA3\_6: see p.11, No. 12)
- (SATA3\_7: see p.11, No. 10)
- (SATA3\_8: see p.11, No. 11)

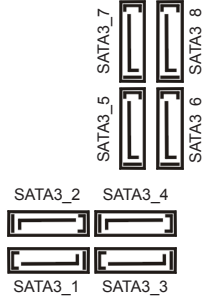

These eight Serial ATA3 (SATA3) connectors support SATA data cables for internal storage devices. The current SATA3 interface allows up to 6.0 Gb/s data transfer rate.

### USB 2.0 Headers

- (9-pin USB\_5\_6)  
(see p.11 No. 21)
- (9-pin USB\_7\_8)  
(see p.11 No. 22)
- (9-pin USB\_9\_10)  
(see p.11 No. 23)

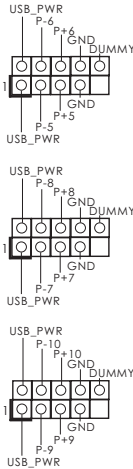

Besides four default USB 2.0 ports on the I/O panel, there are three USB 2.0 headers on this motherboard. Each USB 2.0 header can support two USB 2.0 ports.

### USB 3.0 Header

- (19-pin USB3\_3\_4)  
(see p.11, No. 8)

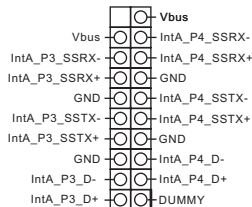

Besides two default USB 3.0 ports on the I/O panel, there is one USB 3.0 header on this motherboard. This USB 3.0 header can support two USB 3.0 ports.

---

## Infrared Module Header

(5-pin IR1)

(see p.11 No. 27)

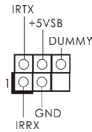

This header supports an optional wireless transmitting and receiving infrared module.

---

## Front Panel Audio Header

(9-pin HD\_AUDIO1)

(see p.11 No. 28)

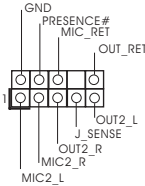

This is an interface for the front panel audio cable that allows convenient connection and control of audio devices.



1. High Definition Audio supports Jack Sensing, but the panel wire on the chassis must support HDA to function correctly. Please follow the instruction in our manual and chassis manual to install your system.
2. If you use AC'97 audio panel, please install it to the front panel audio header as below:
  - A. Connect Mic\_IN (MIC) to MIC2\_L.
  - B. Connect Audio\_R (RIN) to OUT2\_R and Audio\_L (LIN) to OUT2\_L.
  - C. Connect Ground (GND) to Ground (GND).
  - D. MIC\_RET and OUT\_RET are for HD audio panel only. You don't need to connect them for AC'97 audio panel.
  - E. To activate the front mic.  
For Windows® 8 / 8 64-bit / 7 / 7 64-bit 64-bit OS:  
Go to the "FrontMic" Tab in the Realtek Control panel. Adjust "Recording Volume".

---

## System Panel Header

(9-pin PANEL1)

(see p.11 No. 18)

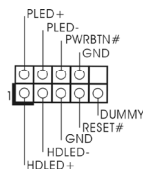

This header accommodates several system front panel functions.



Connect the power switch, reset switch and system status indicator on the chassis to this header according to the pin assignments below. Note the positive and negative pins before connecting the cables.

### **PWRBTN (Power Switch):**

Connect to the power switch on the chassis front panel. You may configure the way to turn off your system using the power switch.

---

**RESET (Reset Switch):**

Connect to the reset switch on the chassis front panel. Press the reset switch to restart the computer if the computer freezes and fails to perform a normal restart.

**PLED (System Power LED):**

Connect to the power status indicator on the chassis front panel. The LED is on when the system is operating. The LED keeps blinking when the system is in S1 sleep state. The LED is off when the system is in S3/S4 sleep state or powered off (S5).

**HDLED (Hard Drive Activity LED):**

Connect to the hard drive activity LED on the chassis front panel. The LED is on when the hard drive is reading or writing data.

The front panel design may differ by chassis. A front panel module mainly consists of power switch, reset switch, power LED, hard drive activity LED, speaker and etc. When connecting your chassis front panel module to this header, make sure the wire assignments and the pin assignments are matched correctly.

---

**Chassis Speaker Header**

(4-pin SPEAKER 1)

(see p.11 No. 20)

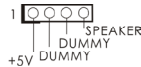

Please connect the chassis speaker to this header.

---

**Power LED Header**

(3-pin PLED1)

(see p.11 No. 19)



Please connect the chassis power LED to this header to indicate system power status. The LED is on when the system is operating. The LED keeps blinking in S1 state. The LED is off in S3/S4 state or S5 state (power off).

---

**Chassis and Power Fan Connectors**

(4-pin CHA\_FAN1)

(see p.11 No. 30)

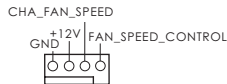

(3-pin PWR\_FAN1)

(see p.11 No. 1)

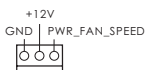

Please connect the fan cables to the fan connectors and match the black wire to the ground pin. CHA\_FAN1 fan speed can be controlled through UEFI or A-Tuning.

### CPU Fan Connectors

(4-pin CPU\_FAN1)

(see p.11 No. 3)

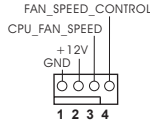

Please connect the CPU fan cable to the connector and match the black wire to the ground pin.



Though this motherboard provides 4-Pin CPU fan (Quiet Fan) support, the 3-Pin CPU fan still can work successfully even without the fan speed control function. If you plan to connect the 3-Pin CPU fan to the CPU fan connector on this motherboard, please connect it to Pin 1-3.

Pin 1-3 Connected ←



3-Pin Fan Installation

(3-pin CPU\_FAN2)

(see p.11 No. 4)

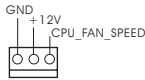

### ATX Power Connector

(24-pin ATXPWR1)

(see p.11 No. 7)

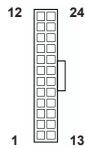

Please connect an ATX power supply to this connector.



Though this motherboard provides 24-pin ATX power connector, it can still work if you adopt a traditional 20-pin ATX power supply. To use the 20-pin ATX power supply, please plug your power supply along with Pin 1 and Pin 13.



20-Pin ATX Power Supply Installation

### ATX 12V Power Connector

(8-pin ATX12V1)

(see p.11 No. 2)



Please connect an ATX 12V power supply to this connector.



Though this motherboard provides 8-pin ATX 12V power connector, it can still work if you adopt a traditional 4-pin ATX 12V power supply. To use the 4-pin ATX power supply, please plug your power supply along with Pin 1 and Pin 5.

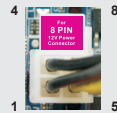

4-Pin ATX 12V Power Supply Installation

---

### Serial port Header

(9-pin COM1)  
(see p.11 No. 26)

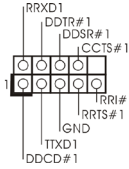

This COM1 header supports a serial port module.

---

### Chassis Intrusion Header

(2-pin C11)  
(see p.11, No. 29)



This motherboard supports CASE OPEN detection feature that detects if the chassis cover has been removed. This feature requires a chassis with chassis intrusion detection design.

---

### Print Port Header

(25-pin LPT1)  
(see p.11, No. 25)

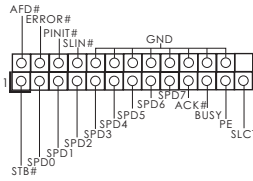

This is an interface for print port cable that allows convenient connection of printer devices.

---

### TPM Header

(17-pin TPMS1)  
(see p.11, No. 24)

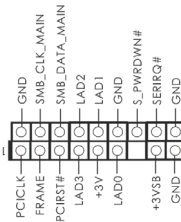

This connector supports Trusted Platform Module (TPM) system, which can securely store keys, digital certificates, passwords, and data. A TPM system also helps enhance network security, protects digital identities, and ensures platform integrity.

---

## 2.7 CrossFire™ and Quad CrossFire™ Operation Guide

This motherboard supports CrossFire™ and Quad CrossFire™ that allows you to install up to two identical PCI Express x16 graphics cards. Currently CrossFire™ and Quad CrossFire™ are supported with Windows® 7 / 7 64-bit / 8 / 8 64-bit OS.



1. You should only use identical CrossFire™-ready graphics cards that are AMD certified.
2. Make sure that your graphics card driver supports AMD CrossFire™ technology. Download the drivers from the AMD's website: [www.amd.com](http://www.amd.com)
3. Make sure that your power supply unit (PSU) can provide at least the minimum power your system requires. It is recommended to use a AMD certified PSU. Please refer to the AMD's website for details.
4. If you pair a 12-pipe CrossFire™ Edition card with a 16-pipe card, both cards will operate as 12-pipe cards while in CrossFire™ mode.
5. Different CrossFire™ cards may require different methods to enable CrossFire™. Please refer to AMD graphics card manuals for detailed installation guide.

### 2.7.1 Installing Two CrossFire™-Ready Graphics Cards

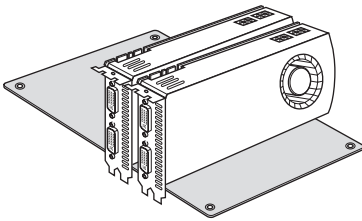

#### Step 1

Insert one graphics card into PCIe1 slot and the other graphics card to PCIe3 slot. Make sure that the cards are properly seated on the slots.



CrossFire Bridge

#### Step 2

Connect two graphics cards by installing a CrossFire Bridge on the CrossFire Bridge Interconnects on the top of the graphics cards. (The CrossFire Bridge is provided with the graphics card you purchase, not bundled with this motherboard. Please refer to your graphics card vendor for details.)

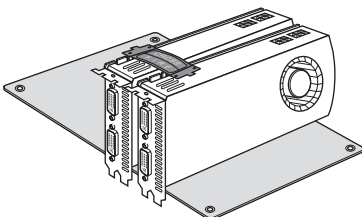

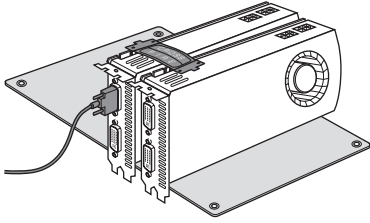

**Step 3**

Connect a VGA cable or a DVI cable to the monitor connector or the DVI connector of the graphics card that is inserted to PCIE1 slot.

---

## 2.7.2 Driver Installation and Setup

### Step 1

Power on your computer and boot into OS.

### Step 2

Remove the AMD drivers if you have any VGA drivers installed in your system.



*The Catalyst Uninstaller is an optional download. We recommend using this utility to uninstall any previously installed Catalyst drivers prior to installation. Please check AMD's website for AMD driver updates.*

### Step 3

Install the required drivers and CATALYST Control Center then restart your computer. Please check AMD's website for details.



AMD Catalyst Control Center

### Step 4

Double-click the **AMD Catalyst Control Center** icon in the Windows® system tray.

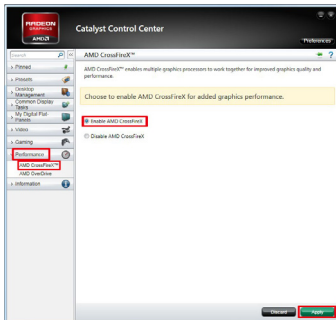

### Step 5

In the left pane, click **Performance** and then **AMD CrossFire™**. Then select **Enable AMD CrossFireX** and click **Apply**. Select the GPU number according to your graphics card and click **Apply**.

---

## 2.8 AMD Dual Graphics Operation Guide

This motherboard supports AMD Dual Graphics feature. AMD Dual Graphics brings multi-GPU performance capabilities by enabling an AMD A88X (Bolton-D4) integrated graphics processor and a discrete graphics processor to operate simultaneously with combined output to a single display for blisteringly-fast frame rates. Currently, AMD Dual Graphics Technology is only supported with Windows® 8 / 7 OS.



### What does an AMD Dual Graphics system include?

An AMD Dual Graphics system includes an AMD Radeon HD 8000/7000 graphics processor and a motherboard based on an AMD A88X (Bolton-D4) integrated chipset, all operating in a Windows® 8 / 7 environment. Please refer to AMD website for further information.

## Enjoy the benefit of AMD Dual Graphics

- Step 1. Please keep the default UEFI setting of “Dual Graphics” option on [Auto].
- Step 2. Install one AMD RADEON PCI Express graphics card to PCIe1 slot.
- Step 3. Connect the monitor cable to the onboard VGA port. Please be noted that the current VGA driver / VBIOS can allow Dual Graphics output from onboard display only. For any future update, please refer to our website for further information.
- Step 4. Boot into OS. Please remove the AMD driver if you have any VGA driver installed in your system.
- Step 5. Install the onboard VGA driver from our support CD to your system for both the onboard VGA and the discrete graphics card.
- Step 6. Restart your computer. Right-click the desktop. Click “AMD VISION Engine Control Center” to enter AMD VISION Engine Control Center.

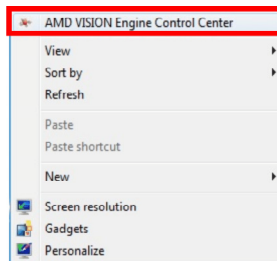

Step 7. You can also click “AMD VISION Engine Control Center” on your Windows® taskbar to enter AMD VISION Engine Control Center.

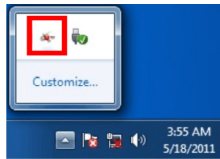

AMD VISION Engine Control Center

Step 8. In AMD VISION Engine Control Center, please choose “Performance”. Click “AMD CrossFire™”.

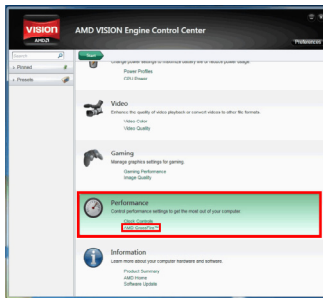

Step 9. Click “Enable CrossFire™” and click “Apply” to save your change.

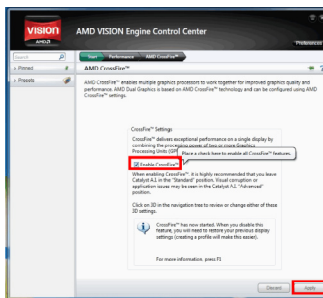

Step 10. Reboot your system. Then you can freely enjoy the benefit of Dual Graphics feature.

- \* Dual Graphics appearing here is a registered trademark of AMD Technologies Inc., and is used only for identification or explanation and to the owners' benefit, without intent to infringe.
- \* For further information of AMD Dual Graphics technology, please check AMD website for up dates and details.

---

## **3. Software and Utilities Operation**

### **3.1 Installing Drivers**

The Support CD that comes with the motherboard contains necessary drivers and useful utilities that enhance the motherboard's features.

#### **Running The Support CD**

To begin using the support CD, insert the CD into your CD-ROM drive. The CD automatically displays the Main Menu if "AUTORUN" is enabled in your computer. If the Main Menu does not appear automatically, locate and double click on the file "ASRSETUP.EXE" in the Support CD to display the menu.

#### **Drivers Menu**

The drivers compatible to your system will be auto-detected and listed on the support CD driver page. Please click Install All or follow the order from top to bottom to install those required drivers. Therefore, the drivers you install can work properly.

#### **Utilities Menu**

The Utilities Menu shows the application software that the motherboard supports. Click on a specific item then follow the installation wizard to install it.

---

## 3.2 A-Tuning

A-Tuning is ASRock's multi purpose software suite with a new interface, more new features and improved utilities, including XFast RAM, Dehumidifier, Good Night LED, FAN-Tastic Tuning, OC Tweaker and a whole lot more.

### 3.2.1 Installing A-Tuning

When you install the all-in-one driver to your system from ASRock's support CD, A-Tuning will be auto-installed as well. After the installation, you will find the icon "A-Tuning" on your desktop. Double-click the "A-Tuning"  icon, A-Tuning main menu will pop up.

### 3.2.2 Using A-Tuning

There are five sections in A-Tuning main menu: Operation Mode, Tools, OC Tweaker, System Info and Tech Service.

#### Operation Mode

Choose an operation mode for your computer.

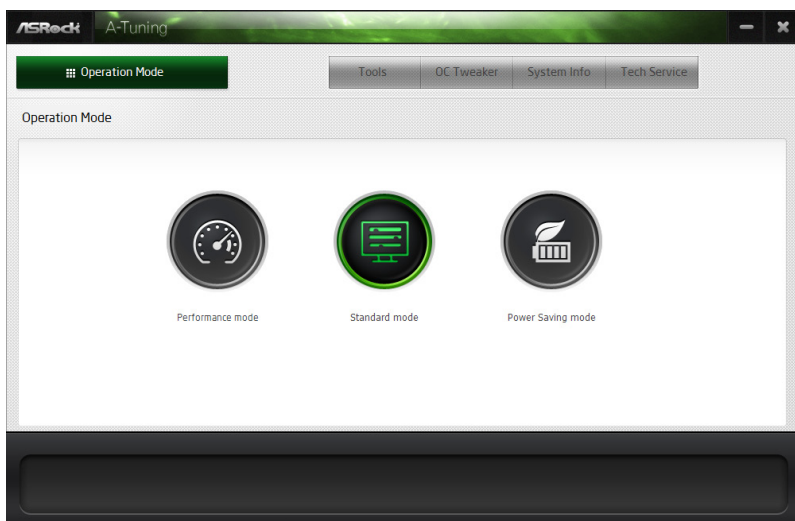

---

## Tools

Various tools and utilities.

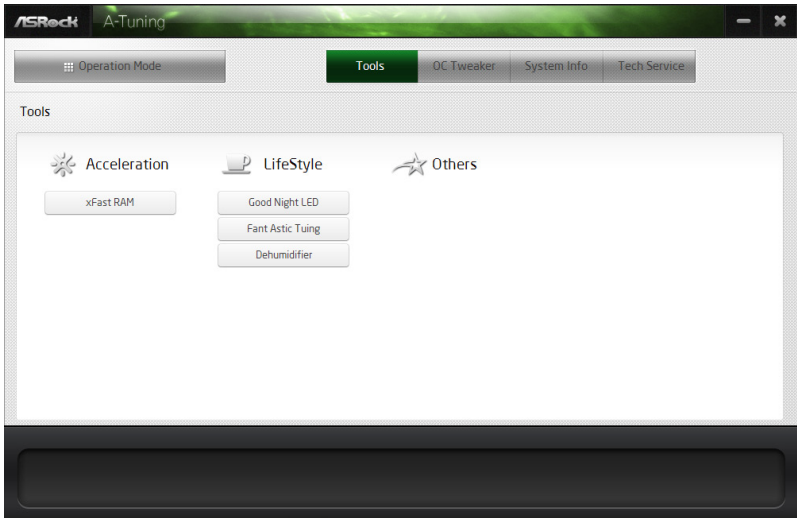

### XFast RAM

Boost the system's performance and extend the HDD's or SDD's lifespan! Create a hidden partition, then assign which files should be stored in the RAM drive.

### Fast Boot

Fast Boot minimizes your computer's boot time. Please note that Ultra Fast mode is only supported by Windows 8 and the VBIOS must support UEFI GOP if you are using an external graphics card.

### OMG

Schedule the starting and ending hours of Internet access granted to other users. Place X marks on the time table to disable the Internet.

### Good Night LED

Switch off the Power/HDD/LAN LEDs when the system is on, and automatically switch off the Power and Keyboard LEDs when the system enters into Standby/Hibernation mode.

---

## FAN-Tastic Tuning

Configure up to five different fan speeds using the graph. The fans will automatically shift to the next speed level when the assigned temperature is met.

## Dehumidifier

Prevent motherboard damages due to dampness. Enable this function and configure the period of time until the computer powers on, and the duration of the dehumidifying process.

## OC Tweaker

Configurations for overclocking the system.

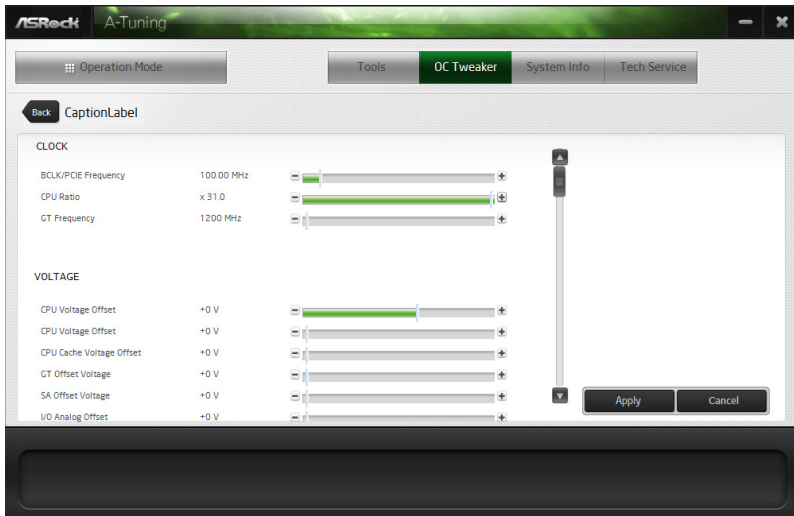

## System Info

View information about the system.

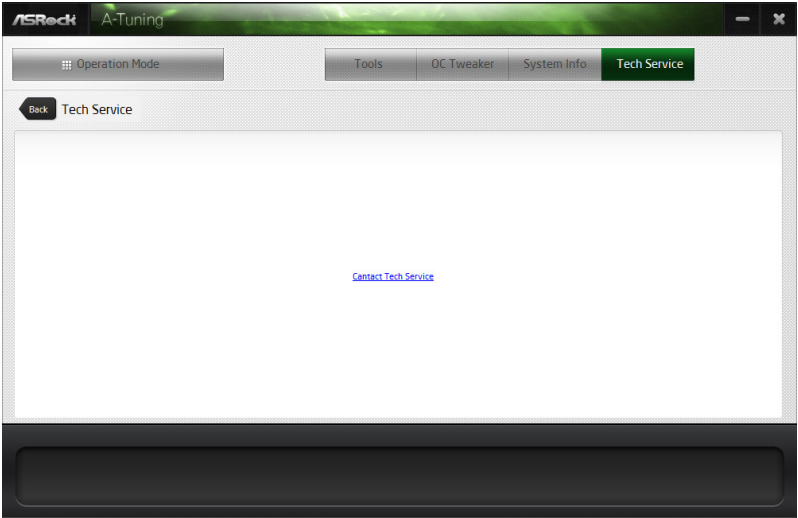

## Tech Service

Contact Tech Service.

---

## 3.3 Qualcomm® Atheros® Security Wake On Internet Technology

Qualcomm® Atheros® Security Wake On Internet Technology allows you to wake up and remote control your home computer from energy efficient sleep mode.

Before configuring this feature, make sure that the "PCI Device Power On" is enabled in UEFI SETUP UTILITY > Advanced > ACPI Configuration.

### 3.3.1 Configuring and Using Sunlogin

Oray Sunlogin is a remote control software that lets you easily access and control the remote host that is installed with the Oray SunLogin Client software.

#### Installing Sunlogin remote client

##### Step 1

Login to [sunlogin.oray.com](http://sunlogin.oray.com).

If you have not created a Sunlogin account, create one.

##### Step 2

Download "Sunlogin Client" from the Download section of [sunlogin.oray.com](http://sunlogin.oray.com) and execute it.



The screenshot shows the Sunlogin website interface. At the top, there is a dark navigation bar with the Sunlogin logo (a yellow sun with a face) on the left, and the text "Sunlogin" in yellow. To the right of the logo are two links: "Home" and "Wake-up stick". Below the navigation bar, the main content area has a light gray background. The title "Sunlogin Client For Windows" is displayed in a large, dark font. Below the title is a horizontal orange line. Underneath the line, there are two links: "Sunlogin Client for Windows package" and "Update History". Below these links, several technical details are listed in a smaller font: "System Support: Win2000 WinXP Win2003 WinVista Win2008 Win7 Win8", "Software Language: English, Simplified Chinese, Traditional Chinese", "Size: 35,189 KB", "Updated on: 2013-03-29", "MD5 value: E412F9998D3809AF7C6F8E94A88B1333", and "Version: 5.3.30.24860". At the bottom of the content area, there is a prominent orange button with the text "Download now" in white.

### Step 3

Click on Remote Client and follow the onscreen instructions to complete the installation.

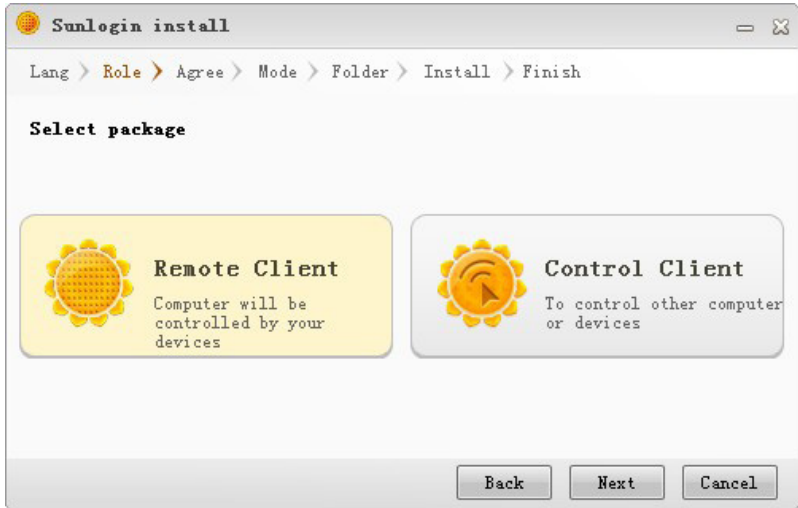

### Step 4

Double-click the Sunlogin Remote Control icon  in the Windows system tray.

### Step 5

Make sure that "Remote wakeup module" and "Remote control module" is set to On.

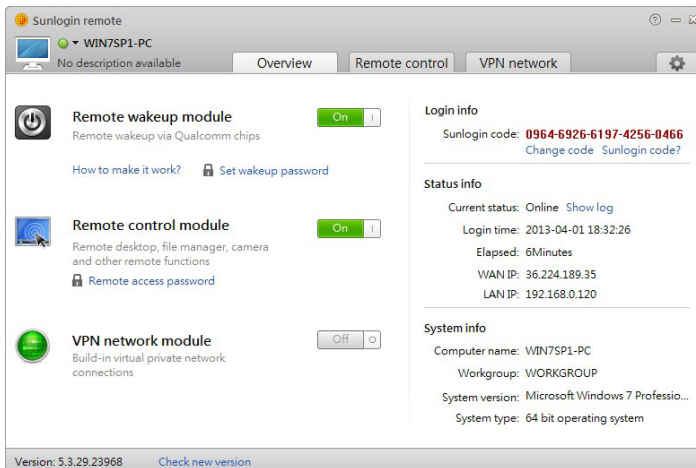

---

## Installing Sunlogin control client

### Step 1

For Windows users:

Download "Control Client" from the Download section of [sunlogin.oray.com](http://sunlogin.oray.com) and execute it. Log-in with your Sunlogin Account and Password.

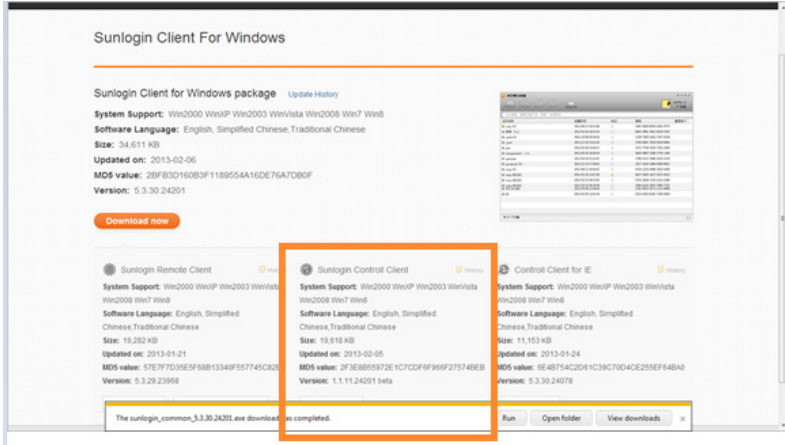

For iPad/iPhone users:

Download "Sunlogin" from the App Store and install the app. Then fill in your Sunlogin Account and Password.

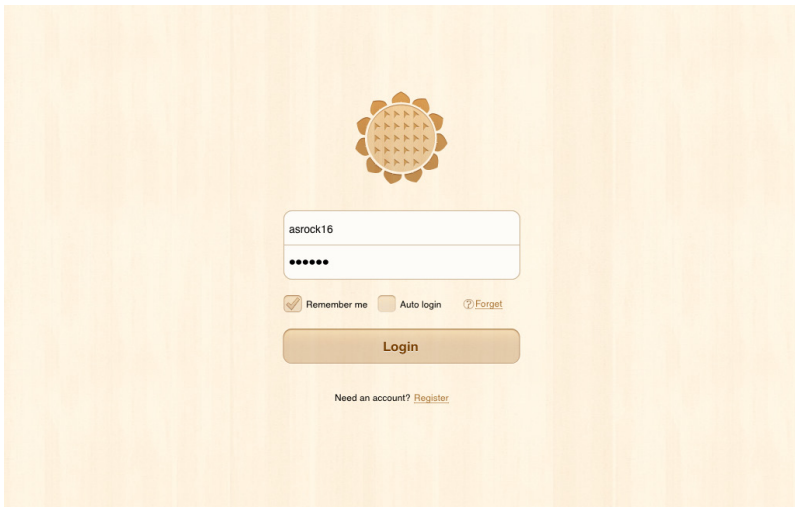

---

For Android mobile device users:

Search “Sunlogin” in Google PLAY and then install the app. Then fill in your Sunlogin Account and Password.



Using Remote Wakeup

For Windows users:

Select one Host (Offline with Gray power button) on the control client panel to wake up your home computer.

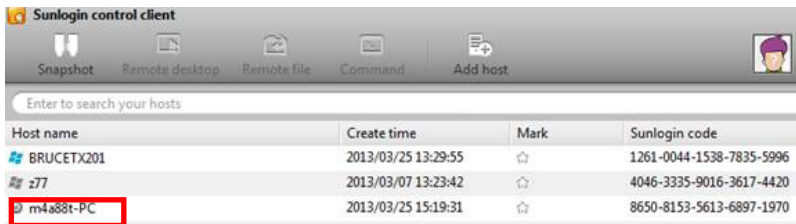

For iPad/iPhone users:

Tap one Host (Offline with Gray power button ) on the Host List. Then tap the Power button to wakeup your home computer.



For Andriod mobile device users:

Tap one Host (Offline with Blue power button ) on the Host List. Then tap the Power button to wakeup your home computer.

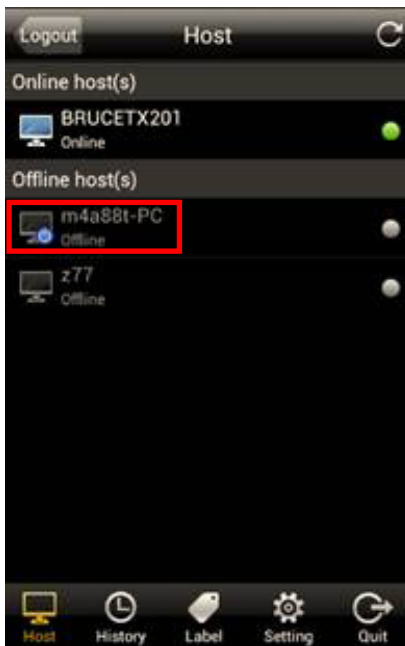

---

## Using Remote Control

For Windows users:

Right-click on a Host (Online with Blue Windows logo) on the control client panel. Then key in your remote access password.

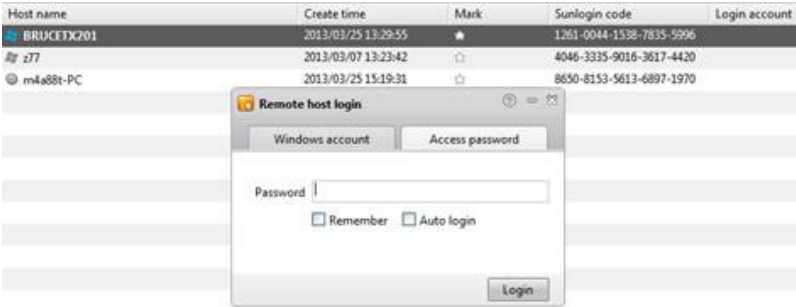

For iPad/iPhone users:

Tap one online machine on the Host List and fill in the Access password to start using remote control.



---

For Andriod mobile device users:

Tap one online machine and fill in the Access password to start using remote control.

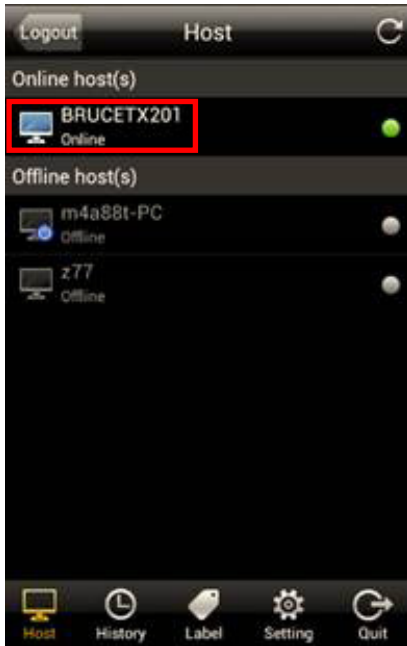

Tutorial Video

---

## 3.4 Start8

For those Windows 8 users who miss the Start Menu, Start8 is an ideal solution that brings back the familiar Start Menu along with added customizations for greater efficiency.

### 3.4.1 Installing Start8

Install Start8, which is located in the folder at the following path of the Support CD: \ASRock Utility > Start8.

### 3.4.2 Configuring Start8

#### Style

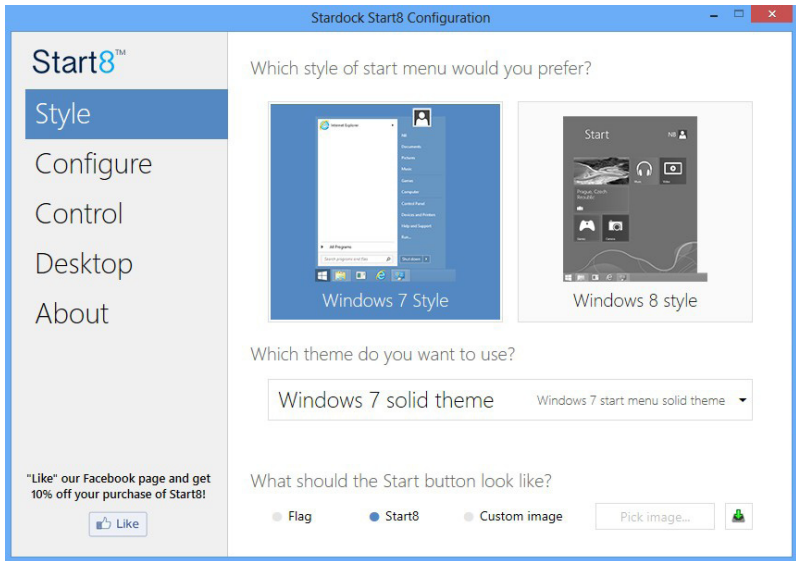

Select between the Windows 7 style and Windows 8 style Start Menu. Then select the theme of the Start Menu and customize the style of the Start icon.

## Configure

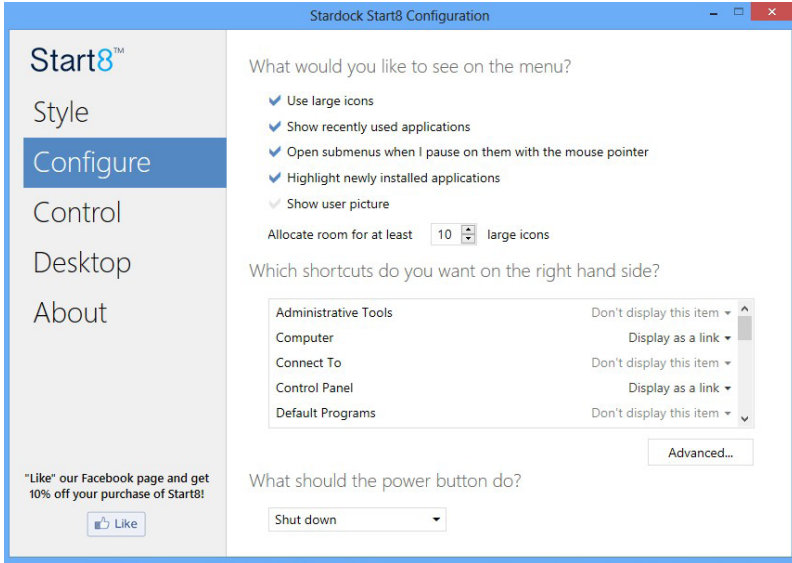

Configure provides configuration options, including icon sizes, which shortcuts you want Start Menu to display, quick access to recently used apps, the functionality of the power button, and more.

## Control

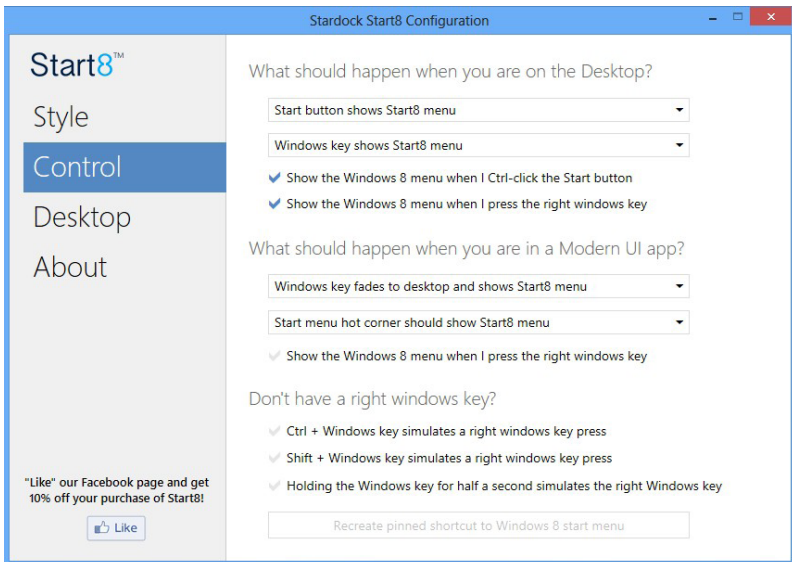

---

Control lets you configure what a click on the start button or a press on the Windows key does.

## Desktop

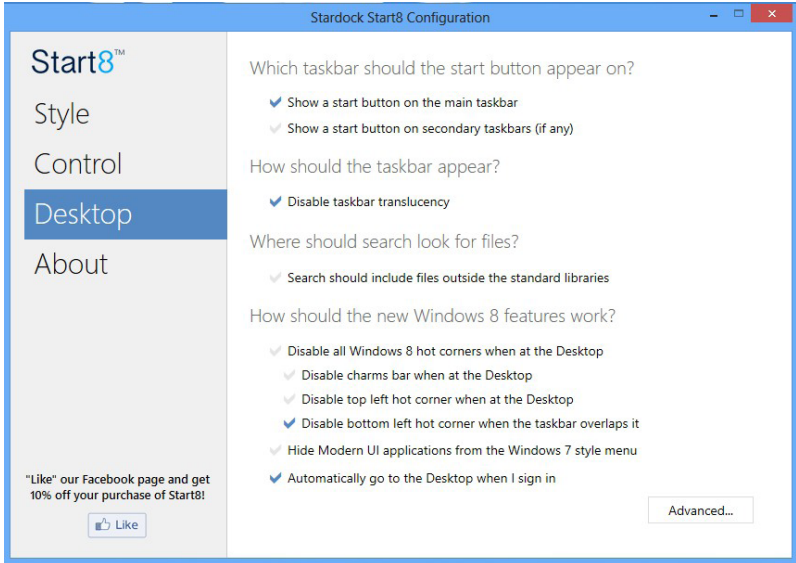

Desktop allows you to disable the hot corners when you are working on the desktop. It also lets you choose whether or not the system boots directly into desktop mode and bypass the Metro user interface.

## About

Displays information about Start8.

---

## 4. UEFI SETUP UTILITY

### 4.1 Introduction

ASRock Interactive UEFI is a blend of system configuration tools, cool sound effects and stunning visuals. Not only will it make BIOS setup less difficult but also a lot more amusing. This section explains how to use the UEFI SETUP UTILITY to configure your system. The UEFI chip on the motherboard stores the UEFI SETUP UTILITY. You may run the UEFI SETUP UTILITY when you start up the computer. Please press <F2> or <Delete> during the Power-On-Self-Test (POST) to enter the UEFI SETUP UTILITY, otherwise, POST will continue with its test routines.

If you wish to enter the UEFI SETUP UTILITY after POST, restart the system by pressing <Ctl> + <Alt> + <Delete>, or by pressing the reset button on the system chassis. You may also restart by turning the system off and then back on.



Because the UEFI software is constantly being updated, the following UEFI setup screens and descriptions are for reference purpose only, and they may not exactly match what you see on your screen.

#### 4.1.1 UEFI Menu Bar

The top of the screen has a menu bar with the following selections:

<b>Main</b>	For setting system time/date information
<b>OC Tweaker</b>	For overclocking configurations
<b>Advanced</b>	For advanced system configurations
<b>Tool</b>	Useful tools
<b>H/W Monitor</b>	Displays current hardware status
<b>Boot</b>	For configuring boot settings and boot priority
<b>Security</b>	For security settings
<b>Exit</b>	Exit the current screen or the UEFI SETUP UTILITY

Use <←> key or <→> key to choose among the selections on the menu bar, and use <↑> key or <↓> key to move the cursor up or down to select items, then press <Enter> to get into the sub screen. You can also navigate with a mouse.

## 4.1.2 Navigation Keys

Please check the following table for the function description of each navigation key.

Navigation Key(s)	Function Description
← / →	Moves cursor left or right to select Screens
↑ / ↓	Moves cursor up or down to select items
+ / -	To change option for the selected items
<Tab>	Switch to next function
<Enter>	To bring up the selected screen
<PGUP>	Go to the previous page
<PGDN>	Go to the next page
<HOME>	Go to the top of the screen
<END>	Go to the bottom of the screen
<F1>	To display the General Help Screen
<F7>	Discard changes and exit the UEFI SETUP UTILITY
<F9>	Load optimal default values for all the settings
<F10>	Save changes and exit the UEFI SETUP UTILITY
<F12>	Print screen
<ESC>	Jump to the Exit Screen or exit the current screen

## 4.2 Main Screen

When you enter the UEFI SETUP UTILITY, the Main screen will appear and display the system overview.



### Active Page on Entry

This allows you to select the default page when entering UEFI setup utility.

---

## 4.3 OC Tweaker Screen

In the OC Tweaker screen, you can set up overclocking features.



### EZ OC Mode

You can use this option to adjust EZ overclocking setting. Please note that overlocking may cause damage to your components and motherboard. It should be done at your own risk and expense.

### CPU Configuration

#### Overclock Mode

Use this to select Overclock Mode. Configuration options: [Auto] and [Manual]. The default value is [Auto].

#### APU/PCIE Frequency (MHz)

This item appears only when you set the item "Overclock Mode" to [Manual]. The default value is [Disabled]. Please be noted that overclocking may reduce the D-Sub resolution and cause the display abnormal situation. It is recommended to use DVI or HDMI monitor to get better performance.

#### Spread Spectrum

This item should always be [Auto] for better system stability.

#### AMD Turbo Core Technology

This item appears only when the processor you adopt supports this feature. Use this to select enable or disable AMD Turbo Core Technology. Configuration options: [Enabled] and [Disabled]. The default value is [Enabled].

#### AMD Application power Management

Application Power Management (APM) ensures that average power consumption over a thermally significant time period remains at or below the TDP for the CPU mode being used. If [Enabled] is selected, the power consumption is reduced when overclocking.

---

**Processor Maximum Frequency**

It will display Processor Maximum Frequency for reference.

**Processor Maximum Voltage**

It will display Processor Maximum Voltage for reference.

**Multiplier/Voltage Change**

This item is set to [Auto] by default. If it is set to [Manual], you may adjust the value of Processor Frequency and Processor Voltage. However, it is recommended to keep the default value for system stability.

**Boost Frequency Multiplier**

For safety and system stability, it is not recommended to adjust the value of this item.

**CPU Frequency Multiplier**

For safety and system stability, it is not recommended to adjust the value of this item.

**Voltage Control Mode**

Use this to control voltage mode.

**CPU Voltage**

It allows you to adjust the value of CPU voltage. However, for safety and system stability, it is not recommended to adjust the value of this item.

**CPU Voltage Offset**

It allows you to adjust the value of CPU voltage offset. However, for safety and system stability, it is not recommended to adjust the value of this item.

**CPU NB Frequency Multiplier**

For safety and system stability, it is not recommended to adjust the value of this item.

**APU Load-line Calibration**

APU Load-line Calibration helps prevent APU voltage droop when the system is under heavy load.

**GFX Engine Clock**

Use this to adjust GFX Engine Clock. The default value is [Auto].

**DRAM Timing Configuration****DRAM Frequency**

If [Auto] is selected, the motherboard will detect the memory module(s) inserted and assigns appropriate frequency automatically.

---

## DRAM Timing Control



### DRAM Slot

Use this item to view SPD data.

### DRAM Timing Control

Use this item to control DRAM timing.

### Power Down Enable

Use this item to enable or disable DDR power down mode.

### Bank Interleaving

Interleaving allows memory accesses to be spread out over banks on the same node, or accross nodes, decreasing access contention.

### Channel Interleaving

It allows you to enable Channel Memory Interleaving. Configuration options: [Disabled], [Auto]. The default value is [Auto].

## Voltage Configuration

### DRAM Voltage

Use this to select DRAM Voltage. The default value is [Auto].

### APU PCIE Voltage VDDP

Use this to select APU PCIE Voltage VDDP. The default value is [Auto].

### SB Voltage

Use this to select SB Voltage. The default value is [Auto].

---

## 4.4 Advanced Screen

In this section, you may set the configurations for the following items: CPU Configuration, North Bridge Configuration, South Bridge Configuration, Storage Configuration, Super IO Configuration, ACPI Configuration, USB Configuration and Trusted Computing.



Setting wrong values in this section may cause the system to malfunction.

---

## 4.4.1 CPU Configuration



### Core C6 Mode

Use this item to enable or disable Core C6 mode. The default value is [Enabled].

### Package C6 Mode

This item appears only when you enable the item “Core C6 Mode”. Use this item to enable or disable Package C6 mode. The default value is [Disabled].

### Cool ‘n’ Quiet

Use this item to enable or disable AMD's Cool 'n' Quiet™ technology. The default value is [Enabled]. Configuration options: [Enabled] and [Disabled]. If you install Windows® 8 / 7 and want to enable this function, please set this item to [Enabled]. Please note that enabling this function may reduce CPU voltage and memory frequency, and lead to system stability or compatibility issue with some memory modules or power supplies. Please set this item to [Disable] if above issue occurs.

### SVM

When this option is set to [Enabled], a VMM (Virtual Machine Architecture) can utilize the additional hardware capabilities provided by AMD-V. The default value is [Enabled]. Configuration options: [Enabled] and [Disabled].

### CPU Thermal Throttle

Use this item to enable CPU internal thermal control mechanism to keep the CPU from overheated. The default value is [Auto].

---

## 4.4.2 North Bridge Configuration



### IOMMU

This allows you to enable or disable IOMMU support.

### Primary Graphics Adapter

This item will switch the PCI Bus scanning order while searching for video card. It allows you to select the type of Primary VGA in case of multiple video controllers. The default value of this feature is [PCI Express]. Configuration options: [Onboard], [PCI] and [PCI Express].

### Share Memory

This allows you to set the share memory feature. The default value is [Auto]. Configuration options: [Auto], [32MB], [64MB], [128MB], [256MB] [512MB], [1GB] and [2GB].

### Onboard HDMI HD Audio

This allows you to enable or disable the “Onboard HDMI HD Audio” feature.

### Dual Graphics

This item appears only when you install AMD RADEON graphics card on this motherboard. Use this to enable or disable Dual Graphics feature. If you enable this option, the primary monitor will be onboard VGA. If you select [Auto], Dual Graphics function will be automatically enabled when you install AMD RADEON graphics card. The default value is [Auto].

### DVI Function

Use this to select DVI function when you install the DVI to HDMI adapter to DVI port. Configuration options: [as Dual Link DVI] and [as HDMI]. If you select [as Dual Link DVI], you can use Dual Link DVI monitor without audio function. If you select [as HDMI], you can use HDMI monitor with audio function. The default value is [as Dual Link DVI].

---

## 4.4.3 South Bridge Configuration



### Onboard HD Audio

Select [Auto], [Enabled] or [Disabled] for the onboard HD Audio feature. If you select [Auto], the onboard HD Audio will be disabled when PCI Sound Card is plugged.

### Front Panel

Select [Auto] or [Disabled] for the onboard HD Audio Front Panel.

### On/Off Play

With ASRock On/Off Play users can connect their portable audio devices, such as an MP3 player or a mobile phone to the PC and listen to music through the computer's speakers even when the computer is turned off.

### Onboard LAN

This allows you to enable or disable the onboard LAN feature.

### Good Night LED

Enable this option to turn off Power LED when the system is power on. The keyboard LED will also be turned off in S1, S3 and S4 state. The default value is [Auto].

---

## 4.4.4 Storage Configuration



### SATA Controller

Use this item to enable or disable the “SATA Controller” feature.

### SATA Mode

Use this item to adjust SATA Mode. The default value of this option is [AHCI Mode]. Configuration options: [AHCI Mode], [RAID Mode] and [IDE Mode].



If you set this item to RAID mode, it is suggested to install SATA ODD driver on SATA3\_5, SATA3\_6, SATA3\_7 and SATA3\_8 ports.

### AMD AHCI BIOS ROM

Use this item to enable or disable AMD AHCI BIOS ROM. The default value of this option is [Disabled].

### SATA IDE Combined Mode

This item is for SATA3\_5, SATA3\_6, SATA3\_7 and SATA3\_8 ports. Use this item to enable or disable SATA IDE combined mode. The default value is [Enabled].



If you want to build RAID on SATA3\_5, SATA3\_6, SATA3\_7 and SATA3\_8 ports, please disable this item.

### Hard Disk S.M.A.R.T.

Use this item to enable or disable the S.M.A.R.T. (Self-Monitoring, Analysis, and Reporting Technology) feature. Configuration options: [Disabled], [Auto], [Enabled].

---

## 4.4.5 Super IO Configuration



### Serial Port

Use this item to enable or disable the onboard serial port.

### Serial Port Address

Use this item to set the address for the onboard serial port.

Configuration options: [3F8h / IRQ4] and [3E8h / IRQ4].

### Infrared Port

Use this item to enable or disable the onboard infrared port.

### Infrared Port Address

Use this item to set the address for the onboard infrared port.

Configuration options: [2F8h / IRQ3] and [2E8h / IRQ3].

### Parallel Port

Enable or disable the Parallel port.

### Device Mode

Select the device mode according to your connected device.

### Change Settings

Select the address of the Parallel port.

---

## 4.4.6 ACPI Configuration



### Suspend to RAM

Use this item to select whether to auto-detect or disable the Suspend-to-RAM feature. Select [Auto] will enable this feature if the OS supports it.

### Check Ready Bit

Enable to enter the operating system after S3 only when the hard disk is ready, this is recommended for better system stability.

### Deep Sleep

Configure deep sleep mode for power saving when the computer is shut down. We recommend disabling Deep Sleep for better system compatibility and stability.

### Restore on AC/Power Loss

This allows you to set the power state after an unexpected AC/power loss. If [Power Off] is selected, the AC/power remains off when the power recovers. If [Power On] is selected, the AC/power resumes and the system starts to boot up when the power recovers.

### PS/2 Keyboard Power On

Use this item to enable or disable PS/2 keyboard to turn on the system from the power-soft-off mode.

### PCI Devices Power On

Use this item to enable or disable PCI devices to turn on the system from the power-soft-off mode.

### Ring-In Power On

Use this item to enable or disable Ring-In signals to turn on the system from the power-soft-off mode.

### RTC Alarm Power On

Use this item to enable or disable RTC (Real Time Clock) to power on the system.

---

**USB Keyboard/Remote Power On**

Use this item to enable or disable USB Keyboard/Remote to power on the system.

**USB Mouse Power On**

Use this item to enable or disable USB Mouse to power on the system.

**ACPI HPET table**

Use this item to enable or disable ACPI HPET Table. The default value is [Enabled]. Please set this option to [Enabled] if you plan to use this motherboard to submit Windows® certification.

**CSM**

Please disable CSM when you enable Fast Boot option. The default value is [Enabled].

---

## 4.4.7 USB Configuration



### USB 2.0 Controller

Use this item to enable or disable the use of USB 2.0 controller.

### A88X USB 3.0 Controller

Use this item to enable or disable the use of USB 3.0 controller.

### Legacy USB Support

Use this option to select legacy support for USB devices. There are four configuration options: [Enabled], [Auto], [Disabled] and [UEFI Setup Only]. The default value is [Enabled]. Please refer to below descriptions for the details of these four options:

[Enabled] - Enables support for legacy USB.

[Auto] - Enables legacy support if USB devices are connected.

[Disabled] - USB devices are not allowed to use under legacy OS and UEFI setup when [Disabled] is selected. If you have USB compatibility issue, it is recommended to select [Disabled] to enter OS.

[UEFI Setup Only] - USB devices are allowed to use only under UEFI setup and Windows / Linux OS.

### Legacy USB 3.0 Support

Use this option to enable or disable legacy support for USB 3.0 devices. The default value is [Enabled].

---

## 4.4.8 Trusted Computing



### Security Device Support

Enable to activate Trusted Platform Module (TPM) security for your hard disk drives.

---

## 4.5 Tool



### System Browser

System Browser can let you easily check your current system configuration in UEFI setup.

### OMG(Online Management Guard)

Administrators are able to establish an internet curfew or restrict internet access at specified times via OMG. You may schedule the starting and ending hours of internet access granted to other users. In order to prevent users from bypassing OMG, guest accounts without permission to modify the system time are required.

### UEFI Tech Service

Contact ASRock Tech Service if you are having trouble with your PC. Please setup network configuration before using UEFI Tech Service.

### Easy RAID Installer

Easy RAID Installer helps you to copy the RAID driver from the support CD to your USB storage device. After copying the drivers please change the SATA mode to RAID, then you can start installing the operating system in RAID mode.

### Easy Driver Installer

For users that don't have an optical disk drive to install the drivers from our support CD, Easy Driver Installer is a handy tool in the UEFI that installs the LAN driver to your system via an USB storage device, then downloads and installs the other required drivers automatically.

### UEFI Update Utility

#### Instant Flash

Instant Flash is a UEFI flash utility embedded in Flash ROM. This convenient UEFI update tool allows you to update system UEFI without entering operating systems first like MS-DOS or Windows®. Just save the new

---

UEFI file to your USB flash drive, floppy disk or hard drive and launch this tool, then you can update your UEFI only in a few clicks without preparing an additional floppy diskette or other complicated flash utility. Please be noted that the USB flash drive or hard drive must use FAT32/16/12 file system. If you execute Instant Flash utility, the utility will show the UEFI files and their respective information. Select the proper UEFI file to update your UEFI, and reboot your system after the UEFI update process is completed.

### Internet Flash

Internet Flash searches for available UEFI firmware updates from our servers. In other words, the system can auto-detect the latest UEFI from our servers and flash them without entering Windows OS.

### Network Configuration



### Internet Setting

Use this item to set up the internet connection mode. Configuration options: [DHCP (Auto IP)] and [PPPOE].

### UEFI Download Server

Use this item to select UEFI firmware download server for Internet Flash. Configuration options: [Asia], [Europe], [USA] and [China].

### Dehumidifier Function

Users may prevent motherboard damages due to dampness by enabling “Dehumidifier Function”. When enabling Dehumidifier Function, the computer will power on automatically to dehumidify the system after entering S4/S5 state.

### Dehumidifier Period

This allows users to configure the period of time until the computer powers on and enables “Dehumidifier” after entering S4/S5 state.

---

**Dehumidifier Duration**

This allows users to configure the duration of the dehumidifying process before it returns to S4/S5 state.

**Dehumidifier CPU Fan Setting**

Use this setting to configure CPU fan speed while “Dehumidifier” is enabled.

**Would you like to save current setting user defaults?**

In this option, you are allowed to load and save three user defaults according to your own requirements.

---

## 4.6 Hardware Health Event Monitoring Screen

In this section, it allows you to monitor the status of the hardware on your system, including the parameters of the CPU temperature, motherboard temperature, CPU fan speed, chassis fan speed, and the critical voltage.



### CPU Fan 1 & 2 Setting

This allows you to set the CPU fan 1 & 2 speed. Configuration options: [Full On] and [Automatic Mode]. The default is value [Full On].

### Chassis Fan 1 Setting

This allows you to set the chassis fan 1 speed. Configuration options: [Full On], [Manual Mode] and [Automatic Mode]. The default is value [Full On].

### Over Temperature Protection

Use this item to enable or disable Over Temperature Protection. The default value is [Enabled].

### Case Open Feature

This allows you to enable or disable case open detection feature. The default is value [Disabled].

### Clear Status

This option appears only when the case open has been detected. Use this option to keep or clear the record of previous chassis intrusion status.

---

## 4.7 Boot Screen

In this section, it will display the available devices on your system for you to configure the boot settings and the boot priority.



### Fast Boot

Fast Boot minimizes your computer's boot time. There are three configuration options: [Disabled], [Fast] and [Ultra Fast]. The default value is [Disabled]. Please refer to below descriptions for the details of these three options:

[Disabled] - Disable Fast Boot.

[Fast] - The only restriction is you may not boot by using an USB flash drive.

[Ultra Fast] - There are a few restrictions.

1. Only supports Windows® 8 UEFI operating system.
2. You will not be able to enter BIOS Setup (Clear CMOS or run utility in Windows® to enter BIOS Setup).
3. If you are using an external graphics card, the VBIOS must support UEFI GOP in order to boot.

### Boot From Onboard LAN

Use this item to enable or disable the Boot From Onboard LAN feature.

### Setup Prompt Timeout

This shows the number of seconds to wait for setup activation key.

### Bootup Num-Lock

If this item is set to [On], it will automatically activate the Numeric Lock function after boot-up.

### Full Screen Logo

Use this item to enable or disable OEM Logo. The default value is [Enabled].

---

## Option ROM Messages

[Force BIOS] - The third-party ROM messages will be forced to display during the bootsequence.

[Keep Current] - The third-party ROM messages will be displayed only if the third-party manufacturer had set the add-on device to do so.

## Boot Failure Guard

Enable or disable the feature of Boot Failure Guard.

## Boot Failure Guard Count

Enable or disable the feature of Boot Failure Guard Count.

## CSM (Compatibility Support Module)



## CSM

Enable to launch the Compatibility Support Module. Please do not disable unless you're running a WHCK test. If you are using Windows® 8 64-bit and all of your devices support UEFI, you may also disable CSM for faster boot speed.

## Launch PXE OpROM Policy

Select UEFI only to run those that support UEFI option ROM only. Select Legacy only to run those that support legacy option ROM only. Do not launch?

## Launch Storage OpROM Policy

Select UEFI only to run those that support UEFI option ROM only. Select Legacy only to run those that support legacy option ROM only. Do not launch?

## Launch Video OpROM Policy

Select UEFI only to run those that support UEFI option ROM only. Select Legacy only to run those that support legacy option ROM only. Do not launch?

---

## 4.8 Security Screen

In this section, you may set or change the supervisor/user password for the system. For the user password, you may also clear it.



### Secure Boot

Enable to support Windows® 8 Secure Boot.

---

## 4.9 Exit Screen



### Save Changes and Exit

When you select this option, it will pop-out the following message, "Save configuration changes and exit setup?" Select [OK] to save the changes and exit the UEFI SETUP UTILITY.

### Discard Changes and Exit

When you select this option, it will pop-out the following message, "Discard changes and exit setup?" Select [OK] to exit the UEFI SETUP UTILITY without saving any changes.

### Discard Changes

When you select this option, it will pop-out the following message, "Discard changes?" Select [OK] to discard all changes.

### Load UEFI Defaults

Load UEFI default values for all the setup questions. F9 key can be used for this operation.

---

## Contact Information

If you need to contact ASRock or want to know more about ASRock, you're welcome to visit ASRock's website at <http://www.asrock.com>; or you may contact your dealer for further information. For technical questions, please submit a support request form at <http://www.asrock.com/support/tsd.asp>

### **ASRock Incorporation**

2F., No.37, Sec. 2, Jhongyang S. Rd., Beitou District,

Taipei City 112, Taiwan (R.O.C.)

### **ASRock EUROPE B.V.**

Bijsterhuizen 3151

6604 LV Wijchen

The Netherlands

Phone: +31-24-345-44-33

Fax: +31-24-345-44-38

### **ASRock America, Inc.**

13848 Magnolia Ave, Chino, CA91710

U.S.A.

Phone: +1-909-590-8308

Fax: +1-909-590-1026